

WATER FUEL CELL™

International News Release

WFC Technical Supplemental Report

Copies may be duplicated for
public release without charge

Information contained
herein not to be used for
manufacturing purposes

Issue No. 11A

Pre-Manufacturing Stage

Fall 1996

WFC Setting Industry Standard

World opens up to Water Fuel Cell

WFC is starting to receive International prominence. An English television broadcasting company, INCA visited WFC in late October 1995. Doing a production for Channel 4, London, their purpose was to highlight Water Fuel Cell in a program entitled "It Runs on Water". Though three technologies were shown, only WFC "Used Water as Fuel"®. Arthur C. Clarke, the noted futurologist was the commentator. The overall theme was very positive. Of particular importance was the focus on Zero Point Energy or Universal Energy, the energy that exists between all atoms. It was stated that the energy output from the Water Fuel Cell seemed like it was tapping into this energy...a technological break through of monumental importance.

The response has been great and continues today. Initially, over 60 letters and faxes requesting information were received. Numerous phone calls were answered and International News Releases sent out. Visits from organizations such as DRA, a division of the Ministry of Defense, and a prestigious British University resulted. A member of the House of Commons contacted WFC and is following WFC progress. One learned author is writing a book on Hydrogen and will feature a chap-

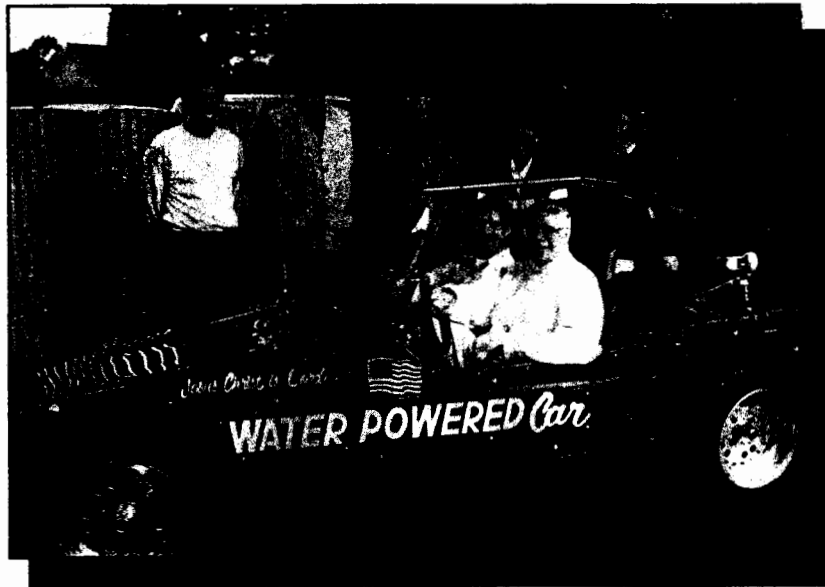

INCA production film crew from London, England are looking on while preparing a one hour documentary on how to use "Water" as a "new" fuel source. The Equinox TV program was broadcast on Sunday night prime-time (7:00 PM) on December 17, 1995. England and many European countries saw the telecast; they are searching for ways to help the environment, while also boosting the European Industrial base. Many industrialists around the world are visiting Grove City, Ohio to negotiate an industrial contract with Inventor, Stanley A. Meyer (sitting behind Dune Buggy steering wheel), for the right to use the WFC Technology of Inventions. WFC Dealerships are being licensed to distribute and install WFC product lines world-wide as pre-modeling WFC energy-kits become a manufacturing reality. Dr. Russell E. Fowler, WFC Executive Director of Personnel and Education, is standing second from the right.

ter on Water Fuel Cell.

The groundwork for this interest was laid by the late Admiral Sir Anthony Griffin, GCB, who was a prime mover toward public awareness of WFC in England. Admiral Griffin, a good friend and supporter of WFC over the years, wrote his own study entitled "Water as Fuel". This comprehensive study discusses the technical, social, environmen-

tal and political impacts of WFC.

Inventor, Stanley Meyer visited England and parts of Europe in late October 1996, holding numerous meetings with industrialists to discuss the viability of WFC technology. This has led to significant discussion concerning WFC "Proof of Concept" contracts (See Page 5) in such areas as aviation, agriculture, home and industrial heating and

Water Fuel Cell, 3792 Broadway, Grove City, Ohio 43123, Phone 1-614-871-4173, Fax 1-614-871-8075

Copyright © 1996 by Stanley A. Meyer

land and water transportation, including the WFC Hyperdrive® technology. Hyperdrive® is essentially an underwater spike engine.

Tapping the Energy of the Atom

Particle Oscillation as an Energy Generator". With these words, Stanley Meyer describes the process, as applied to the Water Fuel Cell™ that has resulted in 26 U.S. and International patents with many more pending. Scientists have long observed that oscillating atoms being stimulated in different ways at a given or particular resonant frequencies results in the release of energy from the atom.

Thomas Edison demonstrated "particle oscillation" very effectively by using current flow to oscillate the atoms of a filament in a light bulb to produce light energy. Gordon Gould used "particle oscillation" by causing an atom to absorb and then reradiate amplified, coherent photon energy in the device known as the LASER. The precursor to the LASER used "particle oscillation" by absorption and reradiation of electromagnetic energy to cause microwave propagation, and is known as the MASER.

A common example of "particle oscillation" by absorbing and reradiating amplified acoustical energy, by using the air molecule atoms in an enclosed space, is the trumpet being blown at an outside sports event. Musical instruments using a sound box amplifies sound waves, thus also using "particle oscillation"

by absorbing and reradiating amplified acoustical energy. This causes the atom to vibrate physically. In all these cases, the atom is absorbing and reradiating different types of energy at an amplified level.

Nature itself demonstrates "particle oscillation as an energy generator" in many ways. What causes lightning or fuels the power in a hurricane or tornado? In each case, the common denominator is the flexing or oscillating of the water molecule.

Lightning is caused when the storm front electrically flexes the water molecule atoms being exposed to opposite electrically charged storm clouds. Flexing of the water molecule present in the vortexing air stream making up or

stream. This stress flexes the atoms electrically to release the energy to power the hurricane or tornado.

Where, then, does this energy come from and how does this energy emanate from the atom?

Under pulsating electrical stress, an energy aperture, located in the nucleus of the atom, is physically forced open to allow a greater amount of energy to come into, through and beyond the energy spectrum of the atom.....releasing energy through the atom into our universe. This was quantified by Einstein's equation, $E=MC^2$. When Einstein squared the speed of light, he realized the potential of light energy was greater than the third dimension in which we exist. This

Universal or Zero Point energy continuously comes into our third dimension through the atoms' energy apertures. It allows all atomic structures in the third dimension either to be created or maintained in the state of atomic equilibrium.

If this were not so, then all life forms as we know them would not exist. How is it that a tiny seed can create a giant redwood tree or the baby in a mother's womb undergo atomic structuring to sustain life? The seed nor the mother does not take in enough solar energy or

food to be able to produce not even one atom. How is that our universe is continuing to expand as mass is being created in our physical universe?

The energy to create the universe and life as we know it seems to emanate from the nucleus of the atom, through the energy aperture. Thus, all atoms function as an "energy generator". This is forcefully



All energy enters into our physical universe (third dimension) through the energy aperture in the nucleus of the atom. This endless sea of Universal Energy now can be harnessed safely to help maintain the economic, ecological and industrial base of the world through use of WFC technology of Inventions.

forming a hurricane or tornado releases tremendous energy that aids in the formation of the storm. An initial temperature rise causes the air to vortex, thus drawing water moisture into the air stream. The vortexing current of air moving upward creates opposite electrical stress across the water molecules present in the electrically charged atmosphere of the moving air

demonstrated by a thermonuclear device which actually opens, then destroys, the energy aperture of the Uranium 235 and 238 atoms.

Until now, the process of oscillating the atom to release energy has required a large energy input. The key is to trigger this process with a low energy input. This makes the process economically feasible and usable to the average consumer. Stanley Meyer was inspired to use voltage fields of opposite polarity across the water molecule to accomplish this feat. This causes electrical stress which causes the atoms of the water molecule to go beyond the state of atomic equilibrium and to disassociate or "split" into hydrogen and oxygen gases.

circuit. Energy is not being created nor destroyed, but released from the atom. (See Drawing on Page 7).

The WFC development of the EASER® technology further harnesses this power, but without destroying the atom and its energy aperture. (See Drawing below). This energy release in the EASER® is caused by simply flexing the hydrogen atom (or any other atom) in a vacuum environment by electrical stress of pulsating opposite voltage potential. The EASER® thus becomes a "Miniature Controllable Sun" under a controlled state.

The most common element on our earth is the hydrogen atom. Hydrogen has been called the perfect fuel because of its great energy

[gtnt] and allow the water molecule to reform to start the gas ignition process over and over without destroying the atomic structure of the water molecule. Thus, man's age old dream can now be realized...to Use Water as Fuel®.

WFC Technology Confirmed

It has taken WFC since 1985 to convince the Scientific Community that their understanding of the water molecule and the forces acting on it needed to be changed. They had to understand that the water molecule is bipolar electrically charged, and that there is an electrical attraction force

between the opposite charged atoms of the water molecule. No electromagnetic force exists between the unlike atoms of the water molecule, since the eight electrons in the outer "L" orbit of the oxygen atoms pair together and spin in opposite directions. The "L" orbit of the oxygen atom accepts up to, but no more than, eight electrons, thus stabilizing the exist-

ence of the water molecule.

The electrical attraction force intensity is equivalent to the two shared hydrogen electrons occupying the "L" orbit of the negatively charged oxygen atom. Applied voltage potential during pulsing of the water molecule is not consumed in the electronic circuit. The "electrical stress" of opposite electric polarity does encourage "particle os-

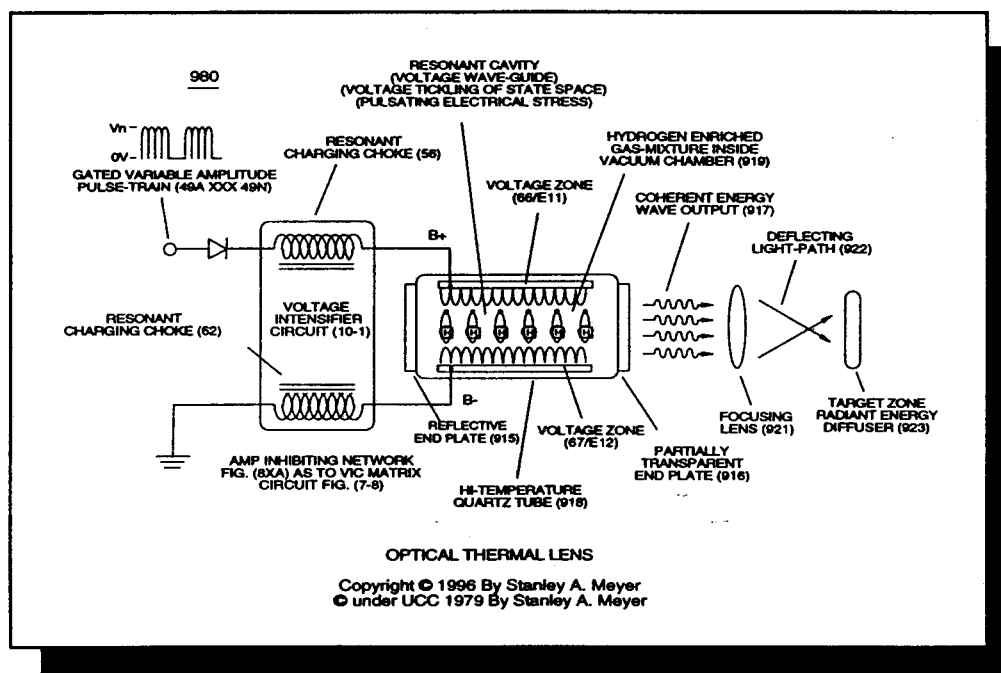

At about 40 kilovolts, the gases automatically ignite, causing thermal explosive energy (gtnt). At even higher voltages, and at the resonant frequency of the water molecule, the energy aperture is opened and tremendous amounts of energy can be released in a controlled state. This unique approach does not consume large amounts of energy since voltage is not consumed in an electronic

and availability. The oxygen atom is the sustainer of our life. The combination of hydrogen and oxygen, which we call water, is both life giving and cleansing. Using water as a clean recyclable energy source is quite apropos. Simply separate the water molecule into its component gases of hydrogen and oxygen, ignite these combustible gases to release thermal explosive energy

cillation as an energy generator". An external "electrical attraction force" is all that is required to dissociate the water molecule; this stress is caused by opposite voltage fields acting on the water molecule. Finally, water droplets can be instantly converted into thermal explosive energy (gtnt) at higher voltage levels (typically up to and beyond 40 kilovolts of pulsating opposite electrical stress).

This information has been confirmed by many scientific journal reports produced by both Government and University test laboratories. Some of the confirming comments follow:

28th Intersociety Energy Conversion Engineering Conference (IECEC), August 1993.

This is an accurate representation of the physical phenomena." "It is verified by the testimony of multiple witnesses and repeated demonstration."

Aeronautic and Space Administration (NASA) Documentation.

"Has significant utility in the conduct of aeronautical and space activities as recited in 42 U.S.C. 2457."

Ray Bachnak, Ph. D., Professor and Chairperson, Electronic Engineering Technology, Franklin University, Columbus, Ohio, 1996.

"Based on the above analysis in my opinion the circuit (VIC) should perform its intended function."

Dr. T. Nagypal, University of Vienna Professor and Technical Consultant Engineer to Industries.

"But your theory works" ... "The relative effectivity is about 300%."

Rea O'Neill, Professor of Science Technology, Dublin Institute of Technology, Dublin, Ireland.

"Meyer has obviously discovered some method of collecting the hydrogen different from the traditional methods (different from the

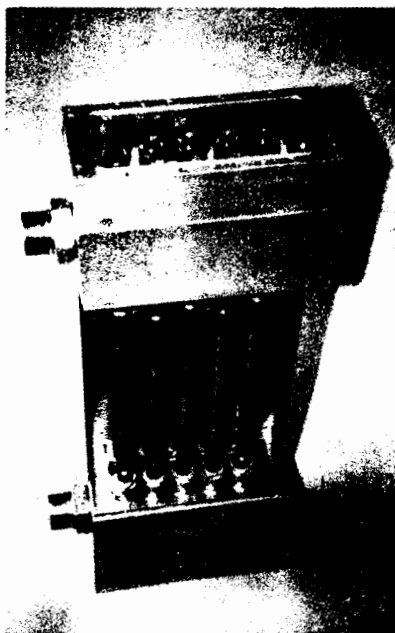

WFC Industrial Steam Resonator ®

This WFC tubular array Steam Resonator® is being developed as an industrial standard under a WFC "Proof of Concept" contract. This particular design will provide instant water heating at different temperature demands during variable weather conditions. Applications include industrial batching processes, home water and air heating systems, and greenhouse and swimming pool heating. Will be used in steam injection for weed control for farming and other agricultural processes. The water molecule is being oscillated under electrical deflection to cause particle impact resulting in kinetic energy release from the water atoms to heat the water. Thus, the Steam Resonator® heats the water without an open flame.

electrolysis process]" ... "I am convinced that the technology demonstrated is a novel and exciting technology and will provide an alternative fuel for use in motor vehicles in the not too distant future."

Admiral Sir Anthony Griffin, Controller of the British Navy (Retired), Perkins Report, 1993.

"Sussex University has succeeded in producing hydrogen from a breadboard rig based on Meyer's circuitry."

Professor Robert Bailey, Mechanical Engineering Department, Ohio State University, Grove City Record Article "Divine Intervention," March 6, 1966.

"There's no doubt that it will work." ... (In reference to the WFC technology).

Professor Paul Czysz, Professor of Aeronautics, St. Louis University and NASA Consultant; Channel 4, London, England; Equinox Program "It Runs on Water"; December 17, 1995.

"Stan Meyer's technology is

characteristic of something that is tapping into Zero Point Energy."

Science Explained, "The World of Science in Everyday Life", Colin A. Ronan, General Editor, Copyrighted Science Book, 1993.

Confirms the fact that liquid and gas molecules take on opposite electrical charges to form polar electrically charged molecules of opposite electrical polarity ... the resultant electrovalent bonding (qq') causing the unlike atoms of the water molecule to become oppositely electrically charged ... the oxygen atom exhibiting a negative electrical charge and the hydrogen atoms exhibiting a positive electrical charge.

Cliffs Notes by Harold D. Nathan, Ph.D. Copyrighted 1993 verify this unusual electrovalent bonding effect between gas and liquid molecular structures in chemical equations by annotating each unlike atomic ion group with either a positive (+) or negative (-) electrical charge symbol between each of the different ionic components.

WFC Contracts in Place

After years of research and development, the WFC technology has entered the system design and pre-manufacturing stage. The rubber starts to meet the road as WFC "Proof of Concept" contracts are being initiated and funded. This means that WFC units/kits are soon expected to be built to manufacturing standards.

Then, however, water must be registered as fuel and the WFC technology tested to EPA and other Government standards and certified. Once that happens, then the WFC objective of "Using Water as Fuel" ® should be open to the world, WFC dealerships should start to flourish and dependence on the polluting fossil fuel comes to an end. It has been a walk of faith throughout the entire WFC journey, and, in faith, WFC objectives are expected to be realized. However, until they are, WFC will work mightily towards that end.

The WFC "Proof of Concept" contract is a unique contract vehicle that protects both WFC and the Contract Assignee. It is a four part contract vehicle useful for the end user and/or mature, high technology company.

The first part, or International WFC Agreement of Acceptance Contract, describes the parameters of the energy system to be modified and establishes particular contract Terms and Conditions that apply to the entire contract. The second part, or International WFC Project Con-

tract, establishes the contract Terms and Conditions for building two prototype WFC units/kit/systems for testing and developing a manufacturing standard for production. WFC provides the design specifications to the Contract Assignee, who builds the prototypes. WFC also furnishes the electronic interfacing and software required to run the WFC unit(s)/kit(s)/system(s).

The third part, or International WFC Patent License Agreement of Acceptance Contract, establishes Terms and Conditions for a manufacturing license for manufacturing

can be retrofitted to huge industrial boilers and will stabilize energy costs for a variety of industries.

An obvious follow-on "Proof of Concept" technology in work is the WFC Industrial Burner Nozzle Assembly ®. (See Drawing below). It's capacity will be in the million BTU/h range, a powerful heating unit. However, this unit can be scaled in size to meet any heating need, from the home heating unit to the megawatt electrical power generating plants. The WFC Burner Nozzle ® can be either retrofittable to an existing system to replace its

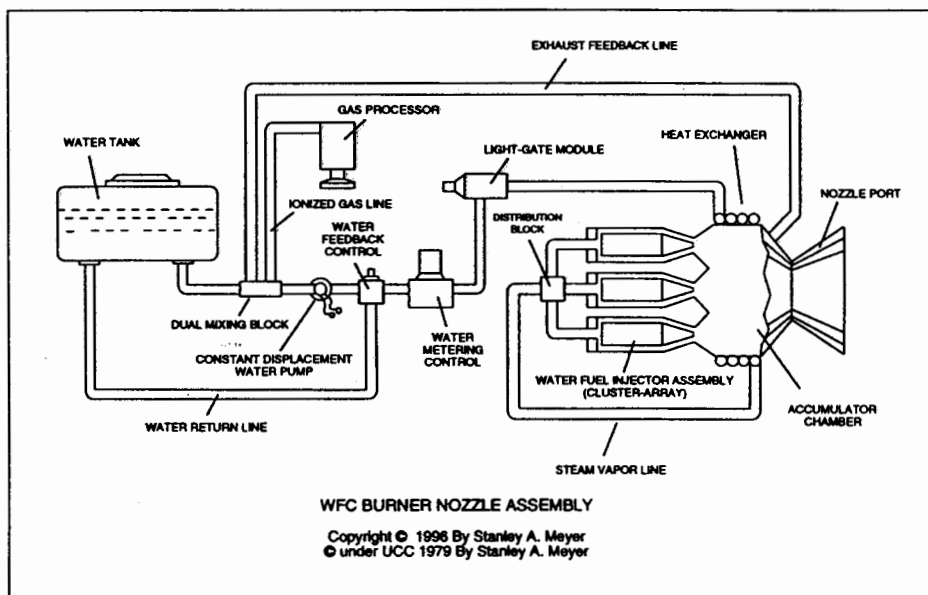

for WFC worldwide distribution. The fourth part, or International WFC Industrial Dealership Contract Agreement, establishes Terms and Conditions for an Industrial Dealership license for a specified geographical area. This license will not conflict with local WFC dealerships, but encourages dealership growth.

WFC encourages multiple contracts in a wide variety of energy areas. The initial thrust is in the industrial/home heating and land transportation fields. A major "Proof of Concept" project in work is the WFC Industrial Steam Resonator ®. (See Photo on page 4). This unit

outdated burners, or can be part of a new heating system. This is one of the advantages of WFC technology; it can be used both for modifying existing systems or developing totally new ones.

Recent contacts of interest have been made for projects in marine, air transportation, desalinization, electrical power generation and waste treatment (both hazardous and nonhazardous). Overseas contacts include England, Germany, Austria, Belgium, Sweden, Canada, Australia, New Zealand, Thailand, India, Korea and the Ukraine. US contacts include Hawaii and Alaska as well

as almost every state. As the US and world prepare to transition into the hydrogen era, WFC will be well postured to meet worldwide energy needs.

Work Continues on WFC Dune Buggy

Everyone asks, "How is the Dune Buggy coming?" In America, there is just a special attraction to running an automobile on water. In England, the attraction is on running a ship on water; in Sweden it's heating one's home. Modifying an automobile is probably one of the most challenging WFC projects because of the variety of systems that must be calibrated with testing procedures for reliability. However, WFC is well within sight of accomplishing this task as the final computer programming is being set. Other electrical components and hardware are being debugged. The WFC Water Fuel Injector [®], where the water droplets are instantly converted in hydrogen and oxygen gases and are ignited in a pulsing voltage field, is also being improved. The Injector is a variant of the WFC Resonant Cavity [®] which enhances the energy output of the WFC pro-

cess. The WFC Resonant Cavity [®] takes on different physical and electrical characteristics to meet the various energy needs. For example, in the automotive transportation area, the Resonant Cavity [®] becomes a WFC Water Fuel Injector [®]. It replaces the standard spark plug in a conventional gasoline or diesel engine without the need for an engine change. The Water Fuel Injector [®] can also be designed in a cluster-array for the application of retrofitting to existing industrial boilers or industrial batching pro-

vert water droplets into thermal explosive energy (gtnt) on demand. This allows the Water Fuel Injection [®] technology to be in compliance with the US National Security Energy Act of 1992.

This Act requires that oxygen must be used in the combustion of the hydrogen gas to run the dune buggy, or any other, internal combustion engine. On new fuels, oxygen must be added to the fuel combustion process. However, one of the beauties of water is that it supplies its own oxygen.

Also, converting the water droplet into instant thermal explosive energy per injection cycle now allows the WFC technology to be in compliance with the US National safety guidelines. These guidelines are met by preventing an explosion during vehicle collision, since water is the safest storage medium for hydrogen. Obviously, hydrogen is contained in the water where it cannot burn.

WFC development of the WFC Air Reclaimer [®] technology is now being perfected to eliminate the possibility of nitrous oxide (laughing gas) or other undesirable gases from being expelled through the vehicle exhaust system.

(See Drawing above) The two to one mix of hydrogen to oxygen in the water molecule is continued throughout the WFC Water Fuel In-

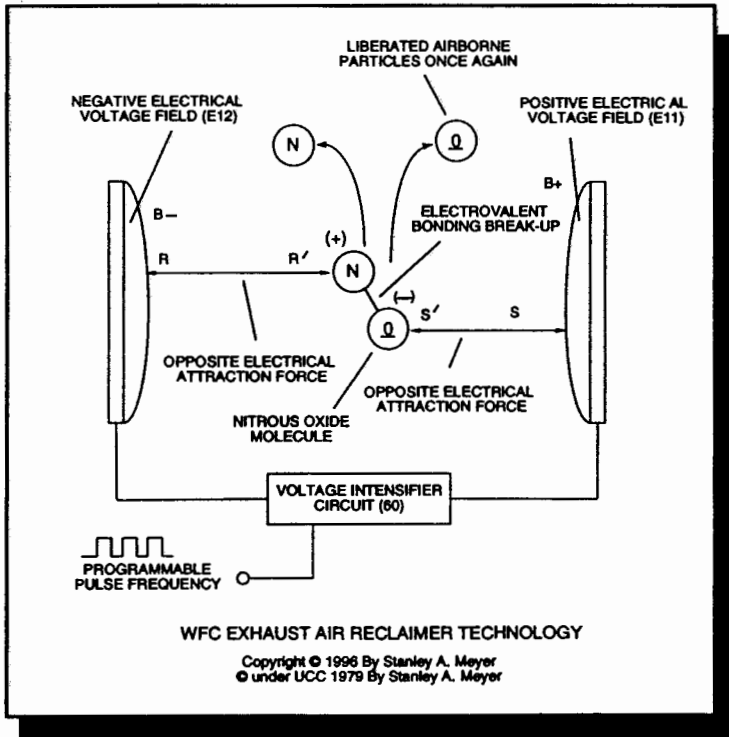

All airborne particles, including chemical oxides present in the air, as a result of burning fossil fuels over the last 70 or so years, can be separated quite easily. Nitrous oxide, generally associated with improper hydrogen combustion in air, is almost non-existent, since the by-product of burning the water gas molecules culminates in the expelling of water mist. If a nitrous oxide molecule is formed, the Air Reclaimer [®] simply separates the nitrous oxide molecule back into its original airborne gases, nitrogen and oxygen.

cesses, as in the WFC Burner Nozzle Assembly [®]. In these cases, the Water Fuel Injectors [®] are specifically designed to instantly con-

jection ® process, thus insuring only negligible amounts of nitrous oxide will be formed. The by-product of the WFC Water Fuel Injection ® process is water mist. This water mist goes back into the environment, and is reenergized by the sunlight (photon energy absorption). Then, it can be caught again as rain water and recycled through the engine. This can be done as either an open or closed loop system.

The WFC technology in using water as a new fuel source, allows the internal combustion engine to help repurify the air by (1) preventing the extraction of oxygen, which we need to breathe, out of the air, (2) eliminating chemical oxides from spewing into our atmosphere as now occurring when fossil fuel is being used as a prime mover, (3) revitalizing the energy levels of the air molecules by the use of the WFC gas processor and (4) separation of chemical oxides that are already present in the atmosphere, placed there by the use of fossil fuels for the past 70 years.

The WFC Air Reclaimer ® technology can overcome the electrovalent bonding of these oxides in the same way the electrovalent bonding of the water molecule is disrupted by placing the oxides through voltage

zones of opposite polarity. Now, the internal combustion engine, instead of being a polluting system, becomes an air purifying system. This reversal for the health and preservation of mankind can be found in few, if any other, technologies. These factors alone, in using water as a new fuel source, is gaining

done to the earth's ecological life support system. This is being supported by the United Nations most recent global announcement that we must stop running vehicles on fossil fuels to prevent further adverse weather conditions caused by global warming. In light of this warning and other obvious signs of grave

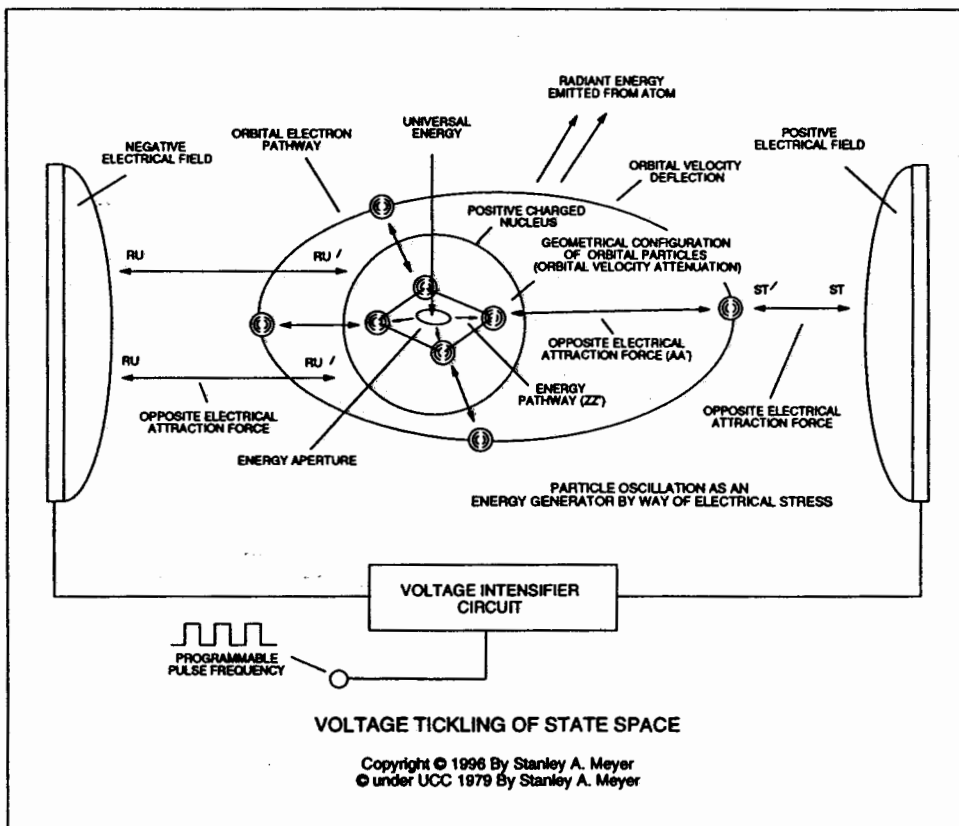

"Particle Oscillation" as an "Energy Generator" by way of pulsating Electrical Stress under atomic resonant is by far the most economical way to release energy from the atom since voltage potential of opposite polarity is not consumed in an electronic circuit. The resultant Electrical Potential to perform work can be adjusted from several kilovolts up to and beyond the million volts range. The delta time (Δt) response to cause the oscillating atom to go from the state of equilibrium to the farthest point away from the state of equilibrium and return to stable state of equilibrium for continued "Energy Priming" is herein known as "Voltage Tickling of State Space." Universal Energy which is, now, passing into, through, and beyond, the atomic structure is an endless, free, and nonpolluting energy source to help maintain the industrial base of the world economy. The wide spread utilization of Universal Energy can allow the Earth Ecological Life Support System to be renewed to help sustain life as we know it.

worldwide acceptance by many environmentalist groups around the earth. These groups are determined to reverse the great harm that's being

danger to our planet, environmentalists around the world are communicating the benefits of WFC technology through the use of the Internet and the World Wide Web.

Using "Water as Fuel"

Most people think of using water for drinking, or washing their clothes, or watering their flowers to beautify their home. Today, we must think of water as a fantastic new fuel source, since water is two and one half times more powerful than gasoline. In the normal gas combustion process in the automobile engine, energy comes from burning the hydrogen in the gasoline. However, water contains two and one half times more hydrogen than gasoline. Now, through WFC technology, the energy in water can be released as thermal explosive energy (gtnt) or (grams tnt force power) in a continuum under safe and efficient control.

This ranges from a release of energy equivalent to more than twice that of gasoline to the equivalent of over two million barrels of oil per gallon of water. The higher energy output is obtained using WFC energy priming techniques, in which the combustible gases from water are taken to subcritical state just prior to gas ignition. See *WFC Tech-Brief titled "The Birth of New Technology" for additional information.*

This is achieved by causing ever

greater pulsating electrical stress across, first, the water molecule and then, the hydrogen and oxygen gas atoms. Starting with the WFC Electrical Polarization Process ® and continuing through the WFC Hydrogen Fracturing Process ®, more and

Water can be instantly converted into thermal explosive energy (gtnt), when opposite electrical stress (voltage) is applied across the bipolar electrically charged atoms of the water molecule. This is accomplished in the WFC Electrical

Polarization Process ®, where the water is dissociated (separated) into hydrogen and oxygen gas atoms. (See Drawing on this page)

In this process, the negative voltage potential (B-) and the equally intense, but opposite, positive voltage potential (B+) overcomes the electrovalent bonding force holding the hydrogen and oxygen atoms together in the water molecule. This causes the negative electrically charged oxygen atom to be electrically attracted to the positive stationary voltage zone (B+), while in the same instant of time, the positively charged hydrogen atoms are electrically attracted to the negative stationary voltage field (B-).

This opposite electrical attraction force performs three functions in a sequence of events in an instant of time: (1) the water molecule now becomes elongated, (2) the time share rate of the electrons in the atomic structure of the hydrogen and gas atoms is changed, thus weaken-

ing the electrovalent bonding between the hydrogen and oxygen atoms, (3) pulsing and increasing the electrical stress across the water molecule weakens the electromag-

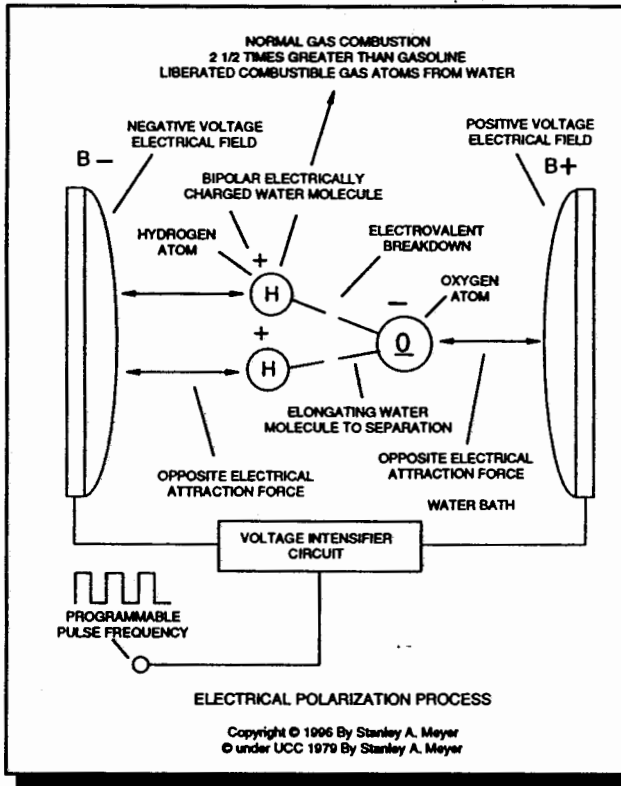

The Electrical Polarization Process simply exposes the bipolar electrically charged water molecule to voltage fields of opposite polarity to physically separate the water molecule into its component gases, hydrogen and oxygen. The negative electrically charged oxygen atom is electrically attracted to the stationary positive voltage field; while, simultaneously, the positive electrically charged hydrogen atom is electrically attracted to the stationary negative voltage field...releasing hydrogen from water that is 2 1/2 times greater than gasoline under normal gas combustion. Increasing pulse voltage amplitude increases gas production. The physical process of using opposite Electrical Attraction Force (Electrical Stress) to pull apart the water molecule is extremely economical, since voltage is not consumed in an electronic circuit.

more energy is released. This is done through techniques that prime the hydrogen and oxygen atoms and open up the energy aperture in the atoms to an increasing degree.

netic field of the combustible gas atoms causing covalent switch-off of the water molecule by reducing the spin/orbital velocity of their electrons undergoing and subjected to electrical stress.

These three steps now allow the water molecule to separate into its component gas atoms with a low energy input. This input is highly voltage dependent and starts in the millivolt/milliamperage range. However, amp leakage is always kept to a minimum, while the voltage increases substantially. Under normal gas combustion in an automobile, the energy equivalent to two and one half times that of gasoline can be released by increasing the voltage level up to and beyond 40 thousand volts (kilovolts). At this voltage level, the hydrogen and oxygen gases automatically ignite as they are disassociated.

This process is economical, since amperage is kept to a minimum and the voltage field of opposite polarity is not consumed in an electrical circuit. It is safe, since pure hydrogen is not stored, but ignited upon demand with the oxygen atoms from the water. Furthermore, the WFC Technology of Inventions does not create energy, but only releases the energy that is already present in the hydrogen and oxygen atoms, thus complying with the Laws of Thermodynamics. When electrically primed, the atoms become and function as *energy generators*. The Laws of Thermodynamics only apply once the energy is released from the atom.

This unique disassociation or splitting of the water molecule was aided by the invention of the WFC Voltage Intensifier Circuit ©. (See

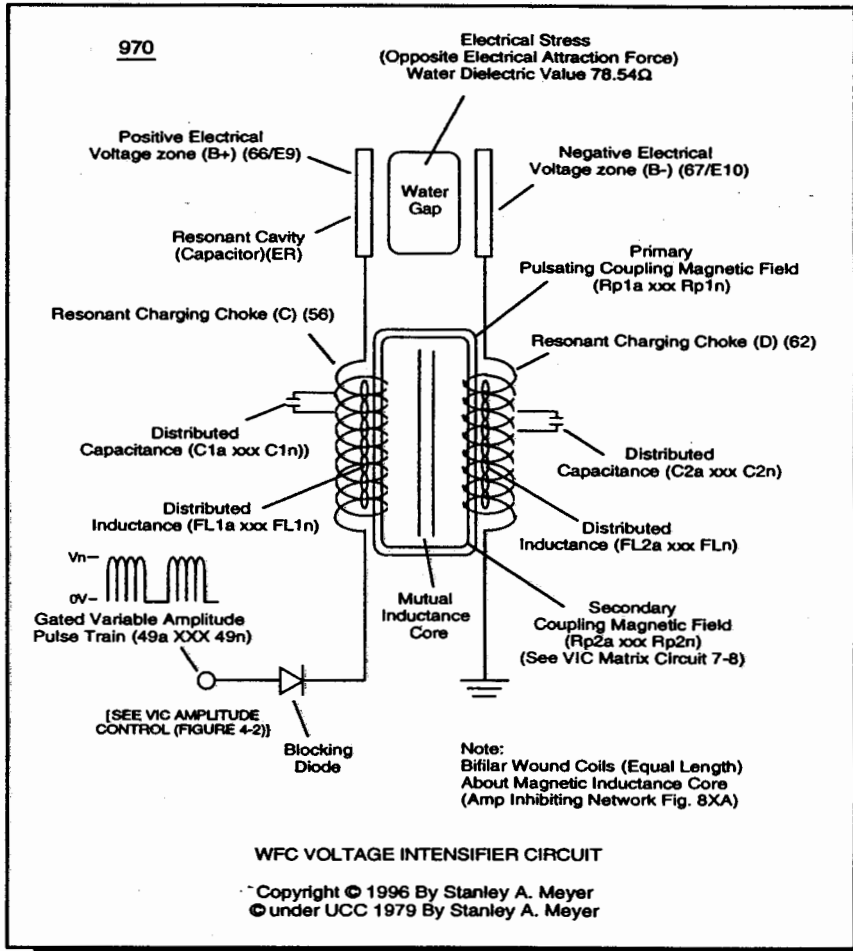

The WFC Voltage Intensifier Circuit (VIC) was especially developed to restrict amp flow while allowing voltage potential of opposite polarity to perform the work of separating the bipolar electrically charged water molecule by way of opposite Electrical Attraction Force known as "Electrical Stress". The distributed self-inductance of each coil inherently prevents amp influxing (retards current flow) across the water gap; while, simultaneously, the distributed capacitance of each coil causes an increase of applied voltage potential of opposite polarity of equal intensity to be placed on opposite sides of the water molecule ... performing the Electrical Polarization Process ©. Each coil further functions as resonant charging choke coils to tune-in to the dielectric properties of water, when the applied pulse frequency is adjusted to incur minimum amp flow, while voltage potential attempts to surge toward infinity if the electronic circuit would allow this to occur. Increasing the number of turns of each coil in direct relationship to increasing applied pulse voltage amplitude increases the electrical stress across the water gap.

Drawing above). The VIC is especially designed to keep amp leakage to a minimal level, to allow the voltage potential of opposite polarity to perform the work required to separate the atoms of the water molecule. This circuit, because of its mutual inductance characteristics and its

unique design, also allows voltage to be increased to the levels needed. The WFC Technology of Inventions can be understood as a series of processes or inventions that lead to the grand result. Each process builds on and enhances what went previously.

First, the WFC Electrical Polarization Process® causes the water molecule to be disassociated into its component gas atoms, hydrogen and oxygen. Then, though it is part of the same process, the pulsating electrical stress is now applied to the released hydrogen and oxygen atoms. As the voltage level is pulsed across the hydrogen and oxygen atoms, the electrons are forced farther

away from the nucleus of the atoms. Their spin/orbital velocity decreases and the atom enters into a state of nonequilibrium. With each recurring pulse, the electrons jump to higher energy levels, as the atom seeks to become stable. This causes the atom to oscillate and the phenomenon of "Energy Release through Particle Oscillation as an Energy Generator" occurs. An incremental step beyond,

the shifting electrons are now ejected away from the elongated atom encountering electrical stress. This decrease in atomic mass flexes the energy aperture even greater ... releasing far greater amounts of thermal explosive energy (gtnt) from the atom than ever before.

WFC Water Fuel Injector®

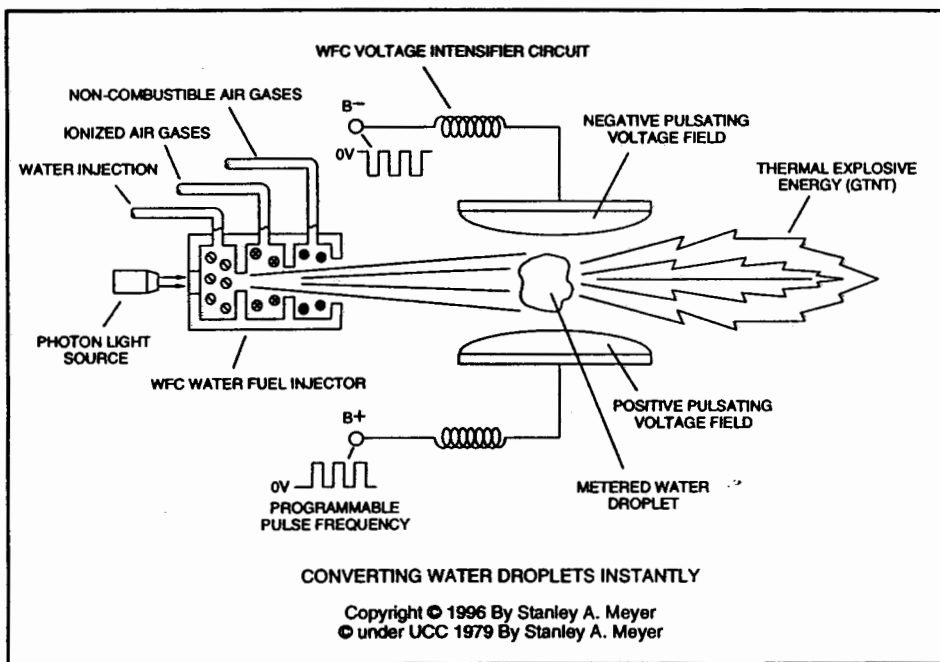

To accomplish this release of energy through the energy aperture of the atom, the WFC Water Fuel Injector was specifically developed. (See Drawing on page 11). Water droplets are metered into the tapered Resonant Cavity functioning as a compressional voltage wave guide. The water droplet being exposed to the high voltage pulses of opposite polarity, instantly converts the water droplets into its component gases (See Drawing on this page). Immediately thereafter, the liberated gases become ionized (Electron Ejection) under increased electrical stress and are finally expelled out of and away from the WFC Water Fuel Injector® nozzle port for gas ignition.

Various, independent university laboratory testing has confirmed the importance of high voltage at low-current in releasing energy from the water molecule. For ex-

Subjecting water droplet(s) to pulsating electrical stress induced by way of voltage potential of opposite polarity can cause the water droplet to instantly convert into thermal explosive energy (gtnt). The addition of noncombustible gases derived from ambient air can adjust the gas combustion rate to coequal fossil-fuel burn-rates; using ionized gases from ambient air can aid energy enhancement of the flame projection; and photon energy absorption sustains the atomic dwell time to allow sufficient spark-ignition of the combustion gases (Hydrogen/Oxygen from water) undergoing and being subjected to pulsating electrical stress. The applied pulse-frequency, applied voltage amplitude, and the volumetric sizing of the water droplet determines the resultant energy yield. No hydrogen fuel storage beyond the properties of water (water does not burn) is required, since water is instantly converted to thermal explosive energy (gtnt) on demand. The component parts of water (one part oxygen, two parts hydrogen) nets the highest energy-yield during hydrogen gas combustion. Of course, the by-product of this energy conversion process is simply water mist. Water supplies its own oxygen to trigger the thermal hydrogen combustion process (gtnt) of using water as a new fuel source. In practical terms, a 7.4 micro liter (μ l) water droplet is all that's required to run a fifty horsepower Internal Combustion (I.C.) Engine per injection cycle; whereas, only a 148 μ l water droplet per injection cycle is required to operate an one thousand horsepower I.C. Engine. See Northeastern University lab report titled "Powerful Water-Plasma Explosion" and Kansas State University Lab Report titled "Electrically Induced Explosion in Water."

ample, Gary L. Johnson,, Kansas State University, in his report titled "Electrically Induced Explosions in Water" discovered that the loudness of the explosion increased as the voltage increased and the volume of the water decreased. Roy Azevedo, Peter Graneau and Charles Millet of Northeastern University and Neal Graneau of King's College London, in their report titled "Powerful Water-Plasma Explosions", confirmed similar results in using pulse-voltage (30 to 40 kilovolt range) to instantly convert water to thermal explosive energy.

The WFC Water Fuel Injector ® is design variable to meet any energy need associated with the burning of fossil fuel. It can replace automobile spark plugs, diesel injectors, injector ports in jet engines and steam turbines, and nozzle ports in water powered rocket engines. In the full systems engineering approach, programmable EEPROM technology of electronic design insures WFC product security and reliability. The WFC Steam Resonator ® technology, previously mentioned on page 4, keeps the water from freezing while using the WFC Water Fuel Injector ® for a given or predetermined application.

By using the oxygen from the water molecule to support hydrogen gas combustion, the WFC Technology of Inventions is under compliance with the US National Security Energy Act of 1992. Recycling water as a new fuel source is achievable,

since the absorption of photon energy from the sun aids in revitalizing the water molecule after gas combustion beyond Voltage Tickling of State Space. The Earth's ecological life support system can now be renewed by preventing the extraction of O₂ from the air during fossil fuel burning. This prevents further depletion of the Ozone Layer by eliminating running jet engines on fossil fuels and diminishes the greenhouse effect by preventing chemical oxides, derived from burn-

ing fossil fuels, from entering into the Earth's air supply.

The use of the WFC Air Reclaimer ® technology can now be used to eliminate airborne chemical oxides that already exist in the Earth's atmosphere as a result of burning fossil fuels over the last seventy to eighty years. Furthermore, The WFC Technology of Inventions lends itself to mass production, since microelectronics and plastic mold injections have been firmly established in the last fifteen years. Δ

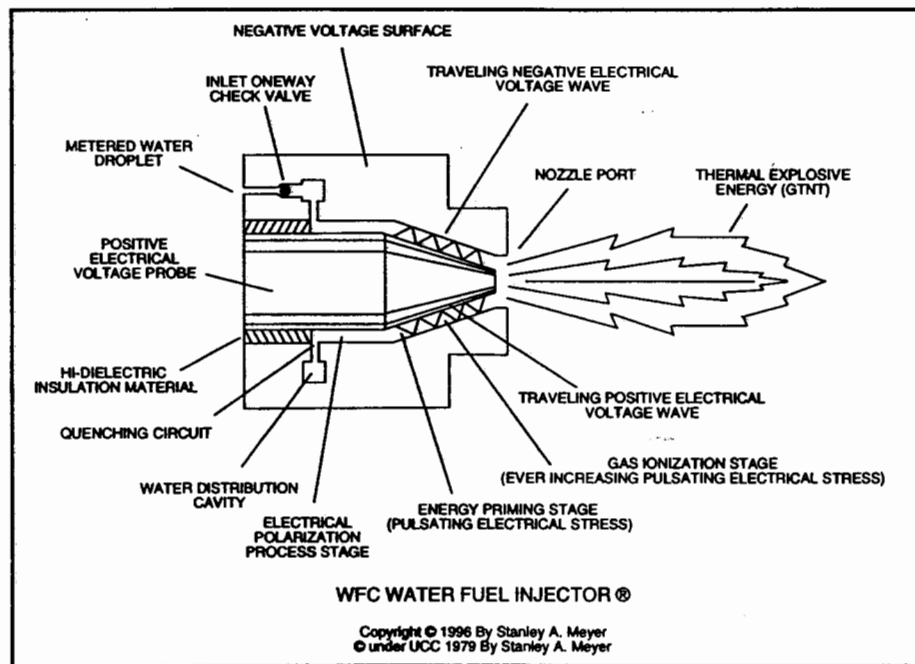

The above WFC Water Fuel Injector ® is design variable to retrofit to any energy consuming device that presently uses fossil-fuels ... such as, but not limited to, replacing spark plugs or fuel-injectors in already existing Internal Combustion gasoline and diesel engines, steam turbines for cogeneration of electrical and heating applications, oil or gas fired nozzle-ports in conventional furnaces, even replacing fuel-nozzles associated with the jet engine. The tapered or "spike" design of the center positive voltage probe intensifies the applied voltage pulse train to continually increase electrical stress across the liberated gases of the water molecule along the entire length of the resonant cavity functioning as a voltage compressional circuit ... thereby, activating the energy priming stage known as "Voltage Tickling of State Space." Typically, the WFC Water Fuel Injector ® performs many sequential functions in an instant of time: liberates the hydrogen/oxygen gases from the injected water droplet; oscillates the free-floating combustible gases under pulsating electrical stress to cause "particle oscillation as an energy generator;" and lastly ionizes the combustible gases by electron ejection prior to the point where the pressurized gases is expelled from the nozzle-port of the WFC Water Fuel Injector ®. As the stretched out (elongated) expelling gases return to stable state of equilibrium, the flexing gas atoms releases the trigger-energy that starts and propagates the gas ignition process for energy utilization.

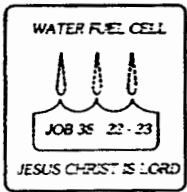

WATER FUEL CELL

INTERNATIONAL NEWS RELEASE

ISSUE No. 10

SYSTEM ENGINEERING DE-BUGGING STAGE

MAY 1994

WFC industrial contracting is now taking place

Military funding is anticipated

By Marcia Thompson

It's been since 1979 in the making, but now it is becoming more and more a reality for Stan Meyer—and people worldwide. Operating vehicles and engines using water as a fuel source is no longer just a dream that is met with skepticism. Laboratories around the world are testing and retesting Meyer's Water Fuel Cell technologies and confirming them to be viable.

On March 15, 1994, Meyer received his 26th major patent on the technology—a systems processing patent pertaining to the internal combustion engine, and other Water Fuel Cell patents are pending.

Meyer has moved cautiously in the development of the Water Fuel Cell technology and systems engineering to avoid technical blockage.

"If any part was blocked by a foreign entity or patent-filing irregularity, the entire process could be blocked," he said. "An inventor could have 99 percent of his work completed, but if he doesn't have that last one percent, everything could be lost."

The next steps will be to complete the on-going pre-engineering stages and de-bug the systems, then look out, World! You may find yourself filling up your



The water-powered dune buggy is now being retrofitted with an up-graded Water Fuel Injection System® utilizing the latest "E-Prom" electronics computer technology to match the acceleration performance of gasoline-driven cars.

vehicle's or other engines' gas tanks with water instead!

Profit-sharing certificates to be offered

It's taken a lot of hard work for many years to reach this stage. Now that Meyer has fully legalized the systems and systems engineering for the Water Fuel Cell technology, he's ready to move toward the next phase of development—that of involving the public in a unilateral movement, along with industry and the military, to obtain funding to bring the technology to the marketplace.

"Funding is critical," Meyer said. "It must be done in such a way that monies coming into Water Fuel Cell for the purposes of

manufacturing retrofit units for distribution and for beginning the Water Fuel Cell International Product Development Center and Trade Center does not jeopardize the technology in any way. With that in mind, we've decided to offer profit-sharing certificates to individuals and investment groups. It will be a limited, international business agreement."

He readily admits that it is a high-risk, high-gain investment—one that will appeal more to the sophisticated investor who can afford the risk of losing that investment.

The initial public offering price will be in the range of \$100 increments up to \$1,000,000 per profit-sharing certificate. Eight

Continued on page two

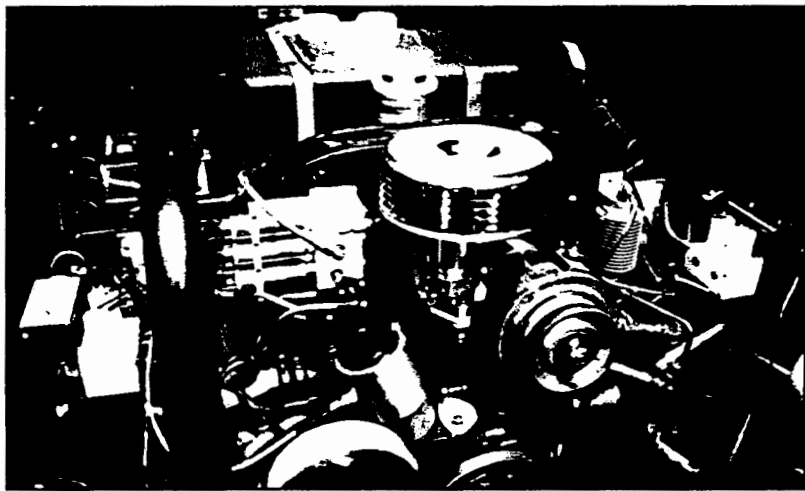

The Water Fuel Injection System is a retrofit energy system being installed on a conventional IC engine without engine change. WFC Injector kits "cost of purchase," when available on the open market, will vary as to the h.p. rating of the IC engine.

Continued from page one

percent of net profits will go per tax year to pay off the certificates, up to a 300 percent return.

Record of filing papers pursuant to U.S. Federal Securities Laws specified under Presidential Executive Order (MPEP 708,021VI—Energy) have been submitted to the U.S. Security and Exchange Commission, Ohio Division of Securities, and to other states' Divisions of Security, including the state of Colorado. Pending final approval of these certificates, then they will be offered to the general public.

"The profit-sharing certificate is a limited business agreement," Meyer noted. "It's not a stock. What we have had to do prior to the issuance of the certificates is to have taken every effort to legalize the technology so it will allow us to set up the Water Fuel Cell Product Development Center."

He said that the technology has been confirmed under 35 U.S. Code 101 (mode of operability...the way and how something is done), the U.S. National Security Energy Act, and the Patent Cooperation Treaty Act, as well as by independent labs around the world.

"The academic world has confirmed that the technology is

viable," he says. "Now the question is, can Stan Meyer complete the systems engineering and get the technology into the marketplace? That answer is yes, positively yes!"

For more details about the profit sharing certificates, contact Stan Meyer, Water Fuel Cell, 3792 Broadway, Grove City, Ohio 43123. Call 1-614-871-4173 between 10 a.m. and 3 p.m. Monday through Friday, Eastern Standard Time, or FAX 1-614-871-8075 anytime.

Research and development center is planned

"We're ready to go into the vendor stage," said Meyer. "We've been in the research and development stage for many years. Now, we'll be allowing industry to come in and aid in the development to get the technology into the economy quickly."

He said that issuing profit-sharing certificates will allow the company to get the product out.

Continued on page three

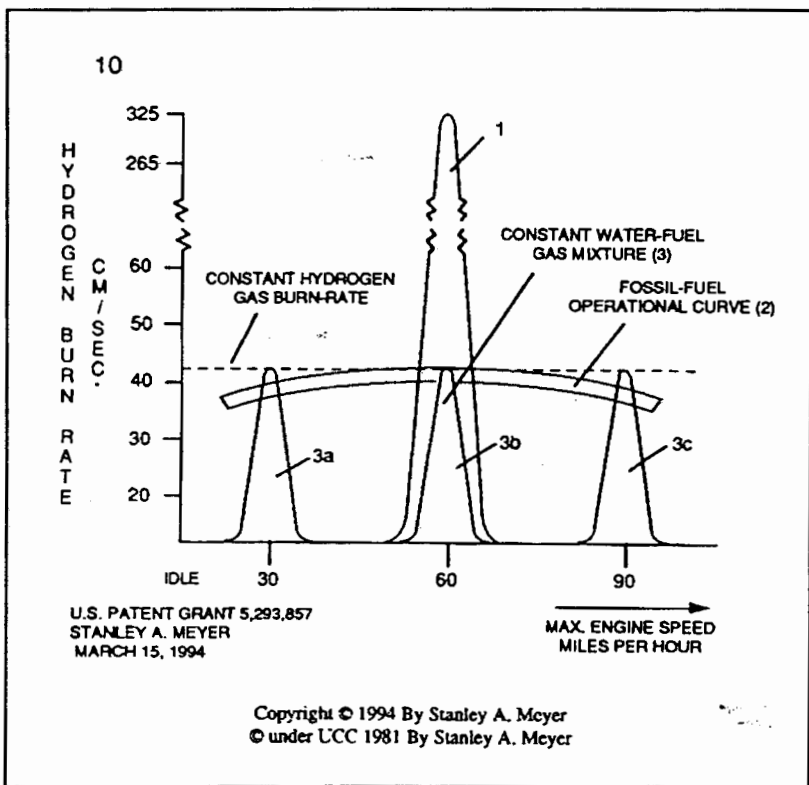

The dune buggy out-performs the fossil fuel operational curve (2) since Water Fuel (3) gas mixing ratio 2:1 (2 hydrogen atoms 1 oxygen atom...component/combustible part of water) and hydrogen burn rate (47 cm/sec.) remains constant regardless of engine acceleration. Using oxygen supplied by the incoming water (3) now brings the Water Fuel Injection System into compliance with the U.S. National Security Energy Act passed in 1992.

Continued from page two

"The profit-sharing certificate is being issued into the international marketplace worldwide, in compliance with the Patent Cooperation Treaty (PCT) Act, as well as in regard to the United States Free Trade Act," Meyer said. "Now, issuing the profit-sharing certificates will allow many people from all over the world from many different walks of life to participate in Water Fuel Cell's future developments."

Plans are progressing for the establishment of the development center in a campus-type design. Land development sites are being considered. In addition to the research complex and international headquarters, proposed parts of the development include a VIP center, recreational facilities, Center for the Performing Arts, a telecommunication/data center, design concept facility, heliport, International Center for Cultural Exchange, a Water Fuel Cell Museum of History, and a college of advanced studies.

Water Fuel Cell would provide the engineering and technology knowledge to aid industry in manufacturing retrofit units to take into mass production for cost effectiveness.

"The Water Fuel Cell Development Center will be truly an international research and development location," Meyer said. "We must all work together as a team to solve energy problems in countries all over the world. We must coordinate between the military and industry to develop the technology for all world entities."

Meyer maintains that it is very important to bring out the technology via private industry if

possible. "However, if there would be a major world catastrophe endangering our fossil fuels energy supply, then governmental assistance from many countries would, hopefully, be forthcoming in order to get the technology out the door and to the marketplace in time to avoid a possible world crisis."

Meyer said many countries are concerned about dwindling energy supplies. Because of the viability of the Water Fuel Cell technology, Meyer has been thrust into the international limelight. It seems that Meyer himself, as well as the Water Fuel Cell project, is more well-known and recognized in other countries than in the United States.

"Many foreign countries and industries worldwide have been

requesting a way they could invest in Water Fuel Cell so they could aid in giving birth to the Water Fuel Cell Development Center," said Meyer. "This is why the profit-sharing certificates are now being legalized to allow this type of funding to come in."

Personnel for the Development Center are being sought

In anticipation of starting the Development Center, appropriate personnel will be needed. Meyer is currently looking for systems and electronic engineers and technicians who are sensitive to the purpose and basic philosophy of Water Fuel Cell. Résumés are now being accepted for multi-media specialists with Macintosh and desktop publishing

skills; full-systems engineers and technical electronic systems engineers who have computer skills that include CAD design, E-Prom computer logic, formatting, and computer chip board layout; general office managers and accountants; project managers with an ability to oversee technical electronic engineering projects from inception to

completion; and electronic technicians who are skilled in project assembly, design, and testing. Requests for

information on submission of résumés should be sent to: Dr. Russell E.

Fowler, Executive Director of Water Fuel Cell Personnel and Education Department, 401 Rick Lane, Indianapolis, IN 46217; Tel/FAX 1-317-787-5226 after 7 p.m. weekdays.

Development of the Water Fuel Cell technology

It's been a long road to get the technology to the stage where it is today. It has meant designing, developing, and making systems component hardware previously not on the market anywhere in the world.

It has meant testing and retesting, which has resulted in changing those same designs, developments, and parts as new technology is introduced.

It has meant downsizing the experimental dune buggy's original electronic system from a box-like computer housing based on integrated circuit design to E-Prom circuitry which is cost-effective in terms of mass production, and finally to a microchip that can perform approximately 1.6 million

Continued on page four



Continued from page three

computer logic functions per second (see photo enlargement on page four). Meyer calls the microchip a major key to the success of Water Fuel Cell.

It has meant complying with patent laws in the United States and other countries to develop the technology and the systems engineering.

And, yes, it has meant taking risks—personal and professional—to do all this in such a way to ensure the technology will develop without receiving technical blockages.

"There are many entities out there who want to keep this technology from reaching it's potential," said Meyer. "The United States, however, has kept its word in allowing the technology to be released into the marketplace. Earlier, there was enormous foreign opposition to the Water Fuel Cell technology; now, we're receiving enormous support from both the United States and foreign countries who have recognized the viability of the Water Fuel Cell technology and want to bring the technology to the marketplace."

An explanation of the Water Fuel Cell technology

Just what is the Water Fuel Cell technology? For the layman, it is advanced hydrogen technology which produces hydrogen gas from natural water. The process is done economically and in an environmentally safe manner. Electrical "atomic" energy is extracted from the water under a controlled means at room temperature. In other words, water can now be considered a viable fuel source in gas as well as electrical generation.

Independent labs around the

world have been testing parts of the technology. Some of those tests include:

- Dr. T. Nagypal of Austria, June 4, 1991—voltage dissociation.
- Kansas State University report #929469 by Gary L. Johnson, January 1992, "Electrically-induced Explosion in Water," which confirmed the Water Fuel Cell mode of operability of the process of instantly converting water into thermal explosive energy on demand, specified under the U.S. National Security Energy Act.
- Northeastern University (Boston) test/report by Azevedo, Graneau,



and Millet titled "Powerful Water Plasma Explosion," July 28, 1986. This test confirmed the use of voltage of opposite electrical attraction forces to instantly convert water into thermal explosive energy.

- Dublin Institute of Technology evaluation report by Rea O'Neill, 1993, which denoted the mode of operability of utilizing particle oscillation of state space as an energy generator.
- Admiral Sir Anthony Griffin (England), Perkins report dated February 28, 1993, a mode of operability report from Sussex University stating success in producing hydrogen from a breadboard rig based on Meyer's

circuitry.

- Dr. Jacob Huber of Kehrsatz, Switzerland, a *raum & zite* magazine article in the January/February 1991 issue, confirming the Water Fuel Cell's energy priming stage.

In the Water Fuel Cell, the 40,000 volts of opposite electrical attraction force at around one milliamperere is all that is required to convert water to explosive thermal energy on demand. This energy is increased through the "voltage tickling of state" space (particle oscillation as an energy generator).

It is spark-ignited by the applied pulse-voltage of opposite electrical voltage polarity, and the energy is released safely. There are four basic processes that occur: 1) electrical polarization process stage; 2) universal energy priming stage; 3) gas ionization stage; and 4) thermal gas triggering stage. These processes occur in a sequence of events in an instant of time.

Eighteen microliters of a water droplet per injection cycle is all that is required to run the experimental dune buggy at 65 m.p.h. down the road. To run a truck, for

example, it would take only 148 microliters of a water droplet to equal the on-road performance of the dune buggy, Meyer said.

Normally, gasoline has .5 pounds of hydrogen in it; whereas water has 1.7 pounds of hydrogen—or 2.5 times that of gasoline. Running a car under the Water Fuel Cell method, you would go 2.5 times farther than on gasoline.

The Water Fuel injectors (see photo enlargement on page three) that replace the conventional spark plugs in an internal combustion engine form the resonant cavity which allows water to be converted to thermal explosive energy. This technology allows the car to run

Continued on page five

Continued from page four

both safely and under control.

Controlling the release of thermal energy in this way has solved some of the problems in the past of using hydrogen as a fuel source:

- Because the water is converted inside the piston, it is a fail-safe system that solves the problem of gasoline explosions.
- It is a 2:1 ratio—two hydrogen

atoms to one oxygen atom. The ratio is maintained when converting the water to explosive gases. This eliminates the hydrogen enrichment problem. The ratio is maintained regardless of the speed of the engine.

- Nitrous oxide formation is held to a minimum.

"When you ignite gases from water, the by-product is a de-energized water mist which goes

out the exhaust," Meyer explained. "It's an open energy system. The water mist is then re-energized by absorbing photon energy from the sun and then returning to the earth's water supply in the form of rain for energy re-use. We can also use a closed, transparent recycling system to keep the vapors from going out into the atmosphere, yet still allow the photon energy

Continued on page six

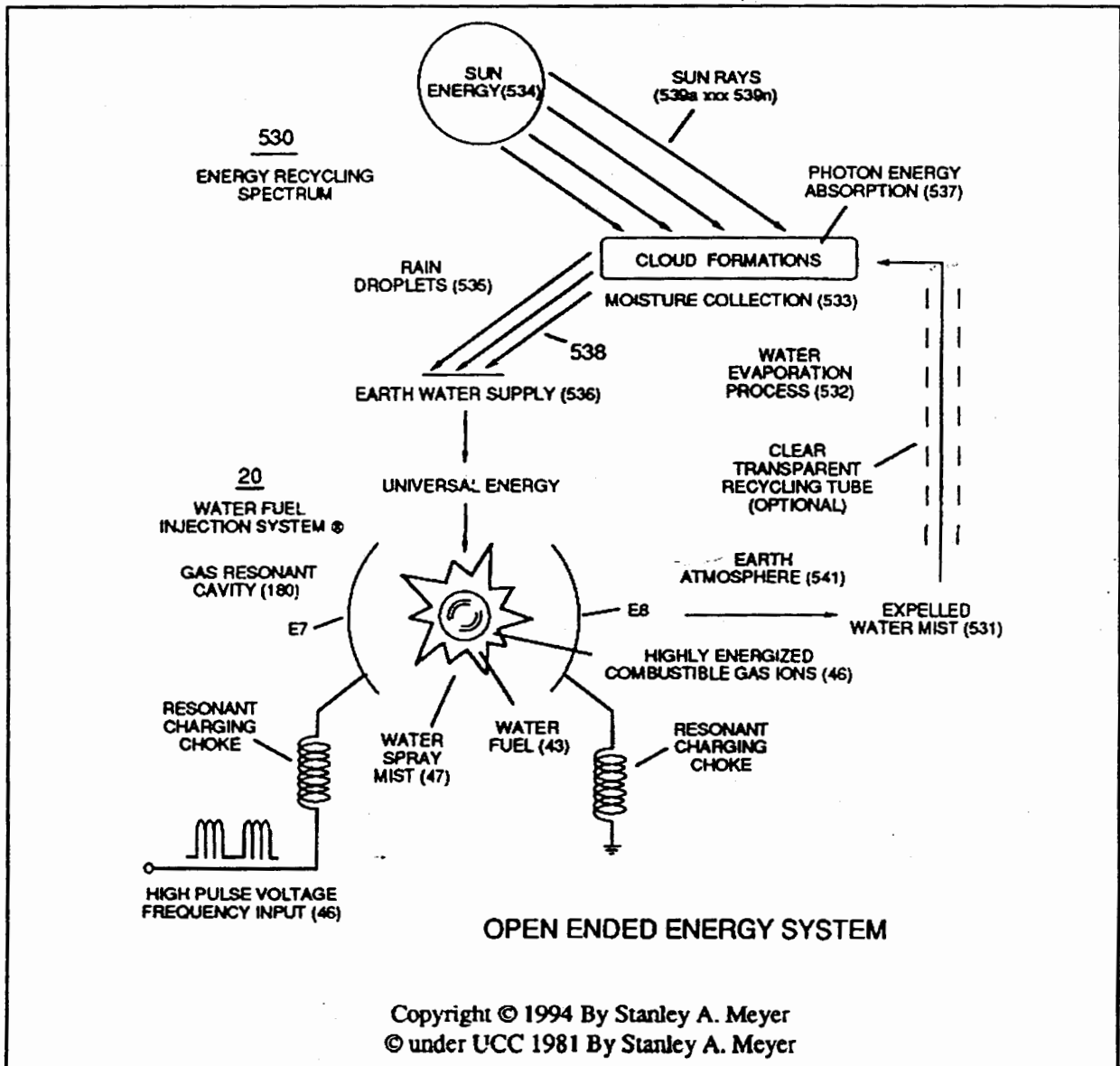

The by-product of exhaust emission of the dune buggy is simply de-energized water mist which, when exposed to the sun rays, becomes re-energized for water reuse, making the Water Fuel Injection System ® an open-ended energy system...running an internal combustion (IC) engine on solar power, as graphically depicted. The expelling water mist absorbs the photon energy from the incoming sun rays instantly; thus, if need be, a closed loop, transparent recycling tube can be utilized when airborne particles are not permitted to enter the Earth's atmosphere. The old-fashioned rain barrel will now take on a new purpose...collecting a clean source of recyclable energy—using water as fuel.

Continued from page five

absorption process to take place. This is now being looked at for possible future use."

Water Fuel Cell technology is specifically designed to be in compliance with Environmental Protection Agency (EPA) non-polluting criteria, as well as highway safety standards in order to make the Water Fuel Cell injection system ecologically acceptable.

"The Water Fuel Cell only uses natural energy present in our environment," said Meyer. "It doesn't add to or subtract from universal energy that is already present in the combustible gas atoms of water. All we have done is tap into this universal energy safely."

Meyer said the U.S. National Security Energy Act of 1992 said that alternative fuel sources must be oxygenated, and the Water Fuel Cell technology complies.

Worldwide pollution problems exist

There are many reasons to seek alternative energy sources—environmental pollution, dwindling supplies of fossil fuels, the economy, fear of radioactive pollution of some oil supplies, and the political instability in many oil-producing countries.

Meyer noted that polar samples show that prior to the Industrial

Revolution, the air was made up of 30 percent oxygen. "Now, that has dropped to less than 21 percent," he said. "As the population increases, and if we continue doing what we're doing to the environment today, the oxygen level will continue to drop, and someday we'll all have to be on respirators in order to breathe."

He says other environmental problems are escalating as a result of our dependence on fossil fuels.

"The pollutants we've put in the air are covalently linking up with the ionosphere and converting the air into a heavy substance that won't sustain life," Meyer said. He said that he recently went back to visit an area in Scandinavia after having been there several years ago. He was shocked to see many trees dying and was told that pollution in that area was becoming so concentrated that available sunlight had diminished by 10 percent. This was allowing a viral germ known as blight to form.

Meyer is also concerned about the Earth's ozone layer. "Most

people think it's being damaged by refrigerants," he said. "That's part of the problem, but I think the most damage is caused by jet engines using fossil fuels and thus releasing pollutants in the upper air regions."

The world is becoming interested in the Water Fuel Cell technology

Meyer is asked to go to many different parts of the world to explain the Water Fuel Cell technology and its advantages to governmental, industrial, and private sectors.

"Many intercession efforts are now being made to legalize the technology in their own countries," Meyer said. "Because we're entering into the vendor stage, it will allow industry to participate in development of proof of concept Water Fuel Cell injection systems to be retrofitted into a given industrial need."

For example, Ireland is coming behind the burner nozzle technol-

Continued on page seven

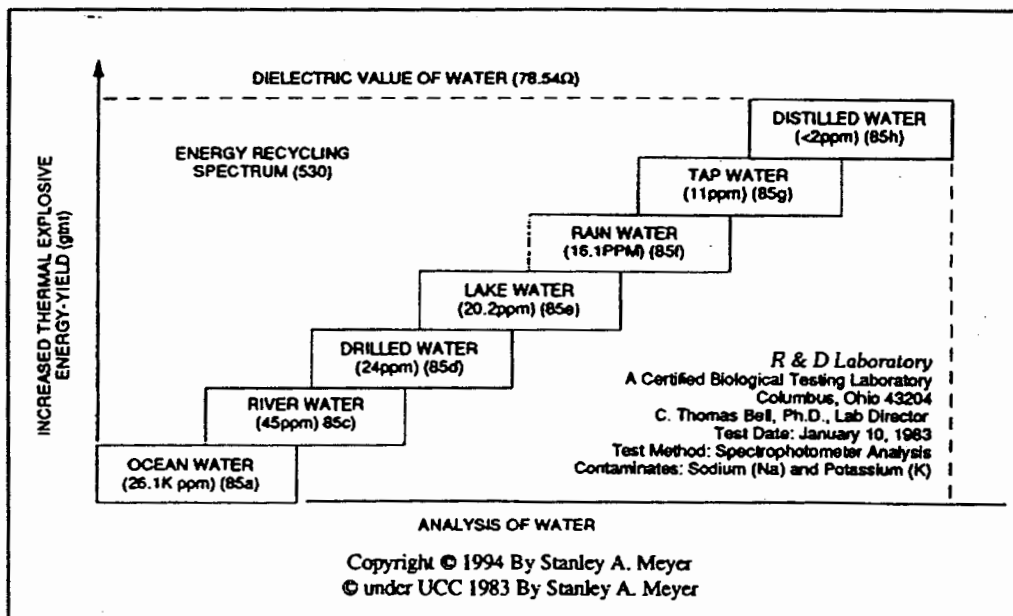

The Water Fuel Injection System © only requires (18) microliters of a water droplet per injection cycle to operate the dune buggy at 65 m.p.h. on the open road; whereas, a truck engine only needs (148) microliters of a water droplet (1/8 dia. 2 cm length column of water) per injection cycle to duplicate the same on-road performance (see WFC International Independent Test/Evaluation Report Binder). The highly energized "rain water" as a "water/fuel" is best suited to purify the air by preventing fossil fuel pollution from taking place.

Continued from page six

ogy to use water as a heat source for boiler application, Meyer said.

He said the garden lawn tractor industry is also interested in the system to operate 12-14 HP engines in order to comply with new environmental regulations pertaining to exhaust emissions.

Other industrial project quotes are taking place in areas of environmental concerns of using water as the primary fuel source, Meyer noted. Just to mention a few, they include:

- The field of transportation to allow cars and trucks to comply with United States emission standards, as well as emission standards in other countries.
- The desalination of salt water for safe and clean drinking water.
- In the areas of toxic waste chemicals and water treatment purification processing.
- In Australia, an indoor ski resort development is looking at the use of Water Fuel Cell technology.
- In burner applications to be used in marketing greenhouses for year-round food production.

A water-powered Indy car is being planned

Racing professionals say that being able to run a race car using the Water Fuel Cell technology would be the greatest improvement in safety in the history of sports car racing.

"We now have the green light to allow us to run an Indy 500 car on the Water Fuel Cell injector technology," Meyer recently announced. "Of course, we would comply with racing safety standards. We can show that the Water Fuel Cell can adjust the burn rate so a water-powered race car could operate equally as well as an alcohol-powered car."

Meyer said sponsorship for funding is now being sought to develop the Indy 500 race car.

"Running a water-powered race car would be a historical event. We have the patents, technology, ideas, and know-how to do it...all we need is the funding. We're looking for individuals or investment groups in all sectors of society— industrial, commercial, and private—who would like to contribute to the development of a proof-of-concept race car," said Meyer.

The funding would allow Water Fuel Cell to purchase an Indy 500 car and related equipment, install the Water Fuel Cell injection system to comply with the specification and safety standards of the Indy 500, and hire a professional driver and independent pit crew, as well as conduct track testing or performance testing to meet operation performance standards of cars currently being used in the race.

"Monies would go strictly to the development of the system and hardware needed to try to successfully win the race," said Meyer. "After all, you don't just want to enter a race...you want to win it. Yes, we would be the underdog, but that's okay. We'd be competing with the best in the field."

As with all Water Fuel Cell

investments and funding, Meyer said there would be strict accounting of every dollar that comes in and how it is spent towards the development of the Water Fuel Cell Indy 500 car technology.

Meyer noted that several things would be proved in developing the race car:

- "It would demonstrate successfully running a car on water."
- "It would demonstrate successfully running a car on water and exceeding the performance of vehicles running on gasoline or alcohol."
- "It would be in compliance with EPA guidelines."
- "It would show the reliability of the system."

He says that a grassroots effort is what will ensure the ultimate success of the Water Fuel Cell.

"It's going to take you, me, and the guy down the street to bring it in in one accord," he said. "No power on Earth can stop us if the people of the world move together on it. We're seeing the formation of groups all over the world that want such an energy system to be developed. With all that powerful, positive thinking—and the help of all those guys down the street—it will happen!"



As shown, the Water Fuel Injector (spark plug replacement) instantly converts a metered water droplet into thermal explosive energy (gtut) when 40,000 voltage potential of opposite electrical stress is pulsed-applied across the injector resonant cavity water gap. Water is 2.5 times more powerful than gasoline.

History In The Making

WFC DEALERSHIP INFORMATION

To attend a WFC Dealership Seminar, call (614) 335-2153 before 7am or after 7pm EST or Fax (614) 871-8075 for scheduling information, or mail request to Water Fuel Cell, 3792 Broadway, Grove City, Ohio 43123 to obtain a WFC Seminar Authorization Pass.

PUBLICATIONS AVAILABLE

The Birth of New Technology: WFC Technical Brief

Explaining the Hydrogen Fracturing Process on how to use "Water" as a new fuel-source. US \$35 plus \$5 postage in U.S. and \$10 for foreign mailing U.S. Currency Only.

WFC Dealership Sales Manual:

Explaining Water Fuel Cell business format and general overview of WFC tech-base and related spin-off developments. US \$30 plus \$5 postage in U.S. and \$10 for foreign mailing. U.S. Currency Only.

WFC News Releases:

Yearly news update on Water Fuel Cell business and product development activities World-wide. US \$ 5 per copy plus \$ 2.50 postage in U.S. and \$ 4.50 for foreign mailing. U.S. Currency Only.

WFC Video Tape:

Titled " The Birth of New Technology" ... " WFC Water Fuel Injection System ® ... Water as Fuel ... Extraordinary Science Talk. US \$30 plus \$5 postage in U.S. and \$10 for foreign mailing. U.S. Currency Only.

WFC International Independent Test-Evaluation Report-manual

Listing of independant "Publications of Reports" conducted by various research laboratories world-wide confirming WFC Technology of Inventions. US \$35 plus \$5 postage in U.S. and \$ 10 for foreiign mailing. U.S. Currency Only.

WFC U.S. Patent Grants Publication of Release

Listing of WFC U.S. Patent Grants Publication of Release in printed format. US \$ 65 plus \$12 postage in U.S. and \$22 for foreign mailing. U.S. Currency Only.

PATENTS GRANTED TO DATE

4,389,981	Hydrogen gas injector system for internal combustion engine (U.S.A.)
4,613,779	Electrical pulse generator (U.S.A.)
4,421,474	Hydrogen gas burner (U.S.A.)
1,231,872	Hydrogen injector system (CDA)
1,233,379	Hydrogen gas injector for internal combustion engine (CDA)
1,228,833	Gas electrical hydrogen generator (CDA)
1,227,094	Hydrogen/air & non-combustible gas mixing combustionsystem (CDA)
4,613,304	Gas electrical hydrogen generator (USA)
1,235,669	Controlled hydrogen gas flame (CDA)
4,275,950	Light-guide lens (USA)
1,234,774	Hydrogen generator system (USA)
3,970,070	Solar heating system (USA)
1,234,773	Resonant cavity hydrogen generator that operates with a pulse voltage electrical potential (CDA)
4,265,224	Multi-stage solar storage system (USA)
1,213,671	Electrical particle generator (CDA)
4,465,455	Start-up / shut-down for a hydrogen gas burner (USA)
4,798,661	Gas generator voltage control circuit (USA)
4,826,581	Controlled process for the production of thermal energy from gases and apparatus useful therefore (Hydrogen Fracturing Process) (PCT)
5,149,407	Process and apparatus for the production of fuel gas and the enhanced release of thermal energy from such gas (Electronic interfacing for the Hydrogen Fracturing Process) (Resonant Action) (U.S.A.)
0101761	Controlled hydrogen gas flame (EPO)
1577992	Controlled hydrogen Gas flame (JPO)
0086439	Hydrogen gas injector system for internal combustion engine (EPO)
1584224	Hydrogen Injection System (JPO)
4,936,961	Method For the production of a Fuel Gas "Electrical Polarization Process" (U.S.A.)
1,694,782	Resonant Cavity For Hydrogen Generator (JPO)
5,293,857	Hydrogen Gas Fuel and Management System for an internal combustion engine utilizing hydrogen gas fuel.
PCT/US91/ 03476	Water Fuel Injection System ® Burner Nozzle (WFC Project 424 DA)

Other U.S. & Foreign Patents Pending

Refer to WFC Profit Sharing Certificate Prospectus when considering purchasing a WFC Dealership or obtaining a WFC Profit Sharing Certificate. (See WFC Dealership Sales Manual).

WFC EMPLOYMENT OPPORTUNITIES

Please send employment resumes and related information to:
 Dr. Russell E. Fowler, WFC Executive Director
 Personnel and Education Department
 401 Rick Lane, Indianapolis, IN 46217
 Tel/Fax: 1-317-787-5226 between 7PM - 9PM EST
 weekdays Only