

# ***THE LAW OF THE SQUARES.***



**THE IMPOSSIBLE MADE POSSIBLE BY FOOLS LIKE SEARL**

**TOMORROW'S TRANSPORT AND ENERGY SYSTEMS.**

**SEARL INTERNATIONAL SPACE RESEARCH CONSORTIUM.**

**BOOK 4B.**

SERIAL NO:000001

THE TEAM PHOTO 1968.

INTRODUCTION TO THE AUTHOR, INVENTOR.

INTRODUCTION TO JOHN THOMAS

PHOTO OF THE MRS & MR SHERWOOD WITH PROF. SEARL

PHOTO OF PROF. SEARL WITH MAG DEMO.

PHOTO OF PROF. SEARL WITH MAG. DEMO.

INTRODUCTION 1989.

PHOTO OF PAPER MODEL CUTOUT

INTRODUCTION 1989.

PHOTO. LUIS JARILLO WITH PROF. SEARL

INTRODUCTION 1989.

PHOTO SUSAN

INTRODUCTION 1989.

PHOTO DOMONIC

INTRODUCTION 1989.

PHOTOS RITA AND JOY

COMPONENTS FOR EVALUATION 1993.

BRAINTEASERS ANSWERS TO BOOK 4A.

IMPOSSIBLE MADE POSSIBLE 1959

IMPOSSIBLE MADE POSSIBLE 1968.

PHOTO DEMO 1 UNDER CONSTRUCTION

MY MEDICAL KNOWLEDGE 1993.

REALITY OR FANTASY 1978.

PICTURE OF ONE OF SEARL'S TRAIN UNITS

SEARL'S RAIL CONTROL SYSTEM 1968.

MY KNOWLEDGE 1946

MY KNOWLEDGE 1946

Take a break 1947.

COMPONENTS FOR EVALUATION 1993.

REALITY OR FANTASY CHOCOLATE 1956.

REALITY OR FANTASY CHOCOLATE 1956

Do not hand me that shit!

REALITY OR FANTASY 1995.

PHOTO JOHN THOMAS WITH PROF. SEARL

REALITY OR FANTASY 1957.

PHOTO NATURE STUDY  
THE HOMO SAPIENS STRUCTURE

REALITY OR FANASY 1957.

PHOTO FEMALE BUM.

REALITY OR FANTASY 1957.

PHOTO HOMO SAPIENS POSTERIOR SKELETON

REALITY OR FANTASY 1957.

PHOTO HOMO SAPIENS ANTERIOR SKELELETON

FACTS 1993.

FACTS 1946.

FACTS.

Fact 27<sup>th</sup> February 1874 coal cutting by machinery

FACTS.

Fact 12<sup>th</sup> September 1941 Technical ability wasted

FACTS.

Fact 24<sup>th</sup> January 1936 Kipling, The Engineer's Poet

FACTS.

Brainteaser No. 1.

FACTS.

11<sup>th</sup> November 1993  
11<sup>th</sup> November 1993

FACTS.

October 1993  
October 1993

FACTS.

Brainteaser No. 2.

DREAM 1 STATES.

PERIODIC TABLE OF THE ELEMENTS 1968.

PERIODIC PROPERTIES OF THE ELEMENTS 1968.

DREAM 1 STATES.

THE SEARL EFFECT.

A German article.

HOMO SAPIENS ATTITUDES 1963.

SEARL UNDERSTANDS FLIGHT 1963.

Skin friction

NEWSLETTER NO. 27. DATE 22.06.1987

STARSHIP EZEKIEL MK.V. AIR LAW 1968.

GENERAL STATEMENTS 1993.

QUESTION TIME 1946.

15 Questions to answer

FINAL REPORT 1956.

I, Prof. John Roy Robert Searl hereby release this book 4B to the public as unclassified matter, upon this date of 25<sup>th</sup> December 1993.



**PROF. JOHN ROY ROBERT SEARL**

**PRESIDENT  
CONSULTANT ENGINEER.**

**SEARL INTERNATIONAL SPACE RESEARCH CONSORTIUM  
DATE RELEASED DECEMBER 25<sup>TH</sup>, 1993.**

**Tomorrow's Energy & Transportation Systems.**

# ***THE LAW OF THE SQUARES***



***This introduction, which shows that work out of star ship Ezekiel MK V, took three people to hold it out to film it. At this date, John Thomas in Rochester New York holds it at his home.***

**JOHN A. THOMAS Jr.**



**Vice President, D.I.S.C.**

- 1 Mr. Thomas has a technical background in electricity and process control.
- 2 He has studied such varied topics as UFO's and Ancient Technology that has been lost or forgotten.
- 3 He has carried on the efforts of Mr. William Sherwood, formerly Professor Searl's contact and helpmate in the **National Space Research Consortium. (NSRC).**
- 4 He first contacted Professor Searl in 1990 and since that, time has printed and distributed his books on "**The Law of the Squares.**"
- 5 John has been a student of Professor Searl and has come to an understanding of "**the Square Technology**" which is the basis for the **Searl Effect Generator (SEG)** and the **Inverse-G-Vehicle (IGV)**
- 6 John is presently Vice President of the **Direct International Science Consortium (D.I.S.C.)** and is Technical Representative for Professor Searl.
- 7 Prof. Searl promised John that he could ride in a small hut pulled behind the **IGV.**





- 1 This is the man who owns the technology termed the **SET**.
- 2 The technology sits in his brain; therefore it cannot be own by anyone else.
- 3 What he states is that he is prepared to form a group to develop this technology.
- 4 That statement means that his dream at this time is in the world of fantasy
- 5 But that dream can and has been defined by structure and function
- 6 Therefore, it is legal for him to state that he has a concept for research and development, and no other person living or dead has the right to that statement.
- 7 It is known that others make belief that they own it, how can them when they have no idea how to do it.



- 7 The concept herein: shall be defined as being a ring and a roller set.
- 8 The purpose of that set is to demonstrate proof of a phenomenon herein termed the '*Searl Effect*'
- 9 Proof of the '*Searl Effect*' being accepted when the roller operates non-stop for 3 days or greater.
- 10 The term '*operate*' refers to that a roller; without any form of assistance commences to rotate around a ring, and continues to do so; without any form of assistance from any other source other than itself.
- 11 This definition defines the concept for research and development.



- 1 Up to this moment in time in which I had been living at No. 13 Blackburn the Following people were involved.



**Luis Jarillo found John Searl and the accommodation at No. 13 Blackburn.**

- 2 That paper work shown on the first page is the scale model of *Starship Ezekiel MK.V*.
- 3 Three people against wall just yards are holding it from *No. 13 Blackburn* protects against the wind.
- 4 I myself work out the structure than cut it out to check that my figures were correct.
- 5 That cut out is held in John Thomas hands in Rochester. USA.
- 6 These are those who were encouraging me to return to this work



**Miss Susanah N. Mutua.**

- 7 First picture is Luis who found me as a lonely down hearted person who had been destroyed by his own family.
- 8 He found the home in which that picture was taken
- 9 The next picture of Susan is that person who gave me her home to live and work so that all humankind could benefit in the end.
- 10 This next picture is Dominic Mutua son of Susan who helped me from time to time with the heavy lifting work.



- 11 That is basic the main story, from the time my first wife destroyed my life and work.
- 12 Susan became my whole life; I work many hours to recover this work under terrible pain conditions.
- 13 All this based upon faith that this time I would succeed to the market place and Susan would become my wife.
- 14 Faith that here at number 13 Blackburn would be my home, and never again would I be lonely and homeless.
- 15 Only time will tell the truth what happen to this work.
- 16 This move to number 13 Blackburn cost me thousands of pound loss.
- 17 Equipment again was needed to be replaced so I could undertake this work.
- 18 Susan went out of her way to help me upon that issue, where no one else made the offer.
- 19 Latter another big problem occurred which would have ended this work, but John Thomas did rush in to save the day.
- 20 Teams form and then disappear.

## **21 WHY?**

- 22 The answer is quite simple. A person informs us that they will have millions in a month's time and wish to invest a million or more to develop this engine.
- 23 The group start to work hard to get ready for full speed ahead as soon as the funds arrive.
- 24 Alas, as always, no funds came, and it is only natural that the hard work put into this without payment cannot continue.
- 25 Therefore, the team slowly breaks up, as it had no purpose to continue if no product could be produced.
- 26 This class of work clicks into millions of £'s or \$'s to develop it to a point in which it could be mass-produced.
- 27 Without that funding there is almost nothing I can do, except to write my life story, which is the Law of the Squares.
- 28 That is also greatly expensive to do.



- 29 Here are two more ladies who helped me in different ways.
- 30 The first was Rita a lifetime friend of Susan; she helped me with the book called the dream that came true.
- 31 The young lady named Joy came into my life right from the moment of her birth, at this age she was communicating with me as a full-grown adult.
- 32 She amazed me with her questions, which clearly showed me that she was reasoning every thing, which she was being taught at school.
- 33 She would give me her feelings on the subject and then ask me what I think about it.
- 34 Her reasoning was sound, her judgement was perfect, in reference to adult women and men who come here to talk, and she was far more intelligent. I enjoyed listening to her reasoning and judgement.

- 35 By the time this photo was taken, she was capable of correctly and quickly works out the answers to extremely large sums, which her mother Phyllis always complained to me that I should not give her such large sums to do.
- 36 However, she loved them, because she loved me so much that she put her heart and soul behind her learning with me.
- 37 This little woman gave me the driving force, not only to make Susan's home lovely but also to speed up the work on this technology, and to record what I did and what was happening around me at that time.
- 38 In return, I gave her love and the power to learn, because she knew I would tell her the truth to all her questions.
- 39 Not only that, but I would listen to all her problems without getting nasty about what she had said.
- 40 It was a bond which is rarely seen between an adult and a child, a bond so great that it became her driving force to learn
- 41 If this bond is ever broken, the power to learn will also be lost for good.
- 42 If a child loses a bond it will result in the lost of ability to learn.
- 43 These books, which I hope I shall live to write will present what has happened to me and how I have responded to each situation involved.
- 44 However, when I am dead that may be all which is left to show the effort which I went to for support to create a new technology which would solve all of our present day problems.
- 45 Yet 80 % of the world's population has no idea that there are any problems, because they fully believe without question that if there were any problems their government would solve that problem.
- 46 Though most people may not believe that there is any problem to worry about, but the very few who do know, many of which go to the extreme state and start to present insane activity, in place of logic thinking.
- 47 Like for example, Aliens will be arriving in the year 2000 to collect all you UFO nut cases and take you to a place of safety.
- 48 Maybe the backside of the Moon or better still on top of a mountain on Mars.
- 49 They are in communications with Aliens, but do not show you their transmitter or receiver so you can order one from your local shop.
- 50 Others are constructing large airships, arming members, and teaching them how to defend themselves and kill. This is the crap, which this planet is loaded with sadly to say but the insanity level is increasing at a much faster rate than ever before from where I sitting.

## COMPONENTS FOR EVALUATION 1993.

- 1 **OCTOBER 4th, 1993**, work has re-started upon my technology, now is the time to evaluate the latest components for selecting the best option for the various functions, which will be required within this technology.
- 2 I know there is just one person who states that people claim that I write bullshit in my books to blind readers with technology.
- 3 I know these people buy these UFO mags and videos and believe absolutely what they state.
- 4 To those people, the truth can never be accepted.
- 5 I do not intend to try to convince them, in **FACT**, the **TRUTH** is, and I have no intentions whatsoever of trying to convince anyone as far as it goes.
- 6 What I am offering to the world is a **CONCEPT FOR DEVELOPMENT** and the **FACTS**, which I can present in support of such a concept, what I actually know, and how to apply that knowledge to such a concept.
- 7 I can propose what components should be considered to meet each function part thereof, to arrive at the best option for success.
- 8 Therefore, everything stated within these books are more precise than that of the bible will ever be in **FACTS**.
- 9 Far more **TRUTHFUL** than the bible is.
- 10 It is a **BIBLE** of absolute **FACTS**, as I know them.
- 11 Only advancement in science and technology can actually update these books.
- 12 That is why there is no end to this story because it is forever extending its bonds in science and technology.
- 13 So let me introduce you to the latest problems, which must be solved for this technology, which has just re-started.
- 14 The hydraulic connection between an agricultural implement and a tractor as shown below is now an easier task with these Pioneer multi-couple.
- 15 Now such a concept could very well be applied to the slender disc project for the flight cell function.
- 16 In the above figure, that system connects up to seven hydraulic lines and six electrical lines in a single operation.
- 17 Well done!
- 18 Two heavy-duty die cast aluminium housings hold the quick couplings during connection.



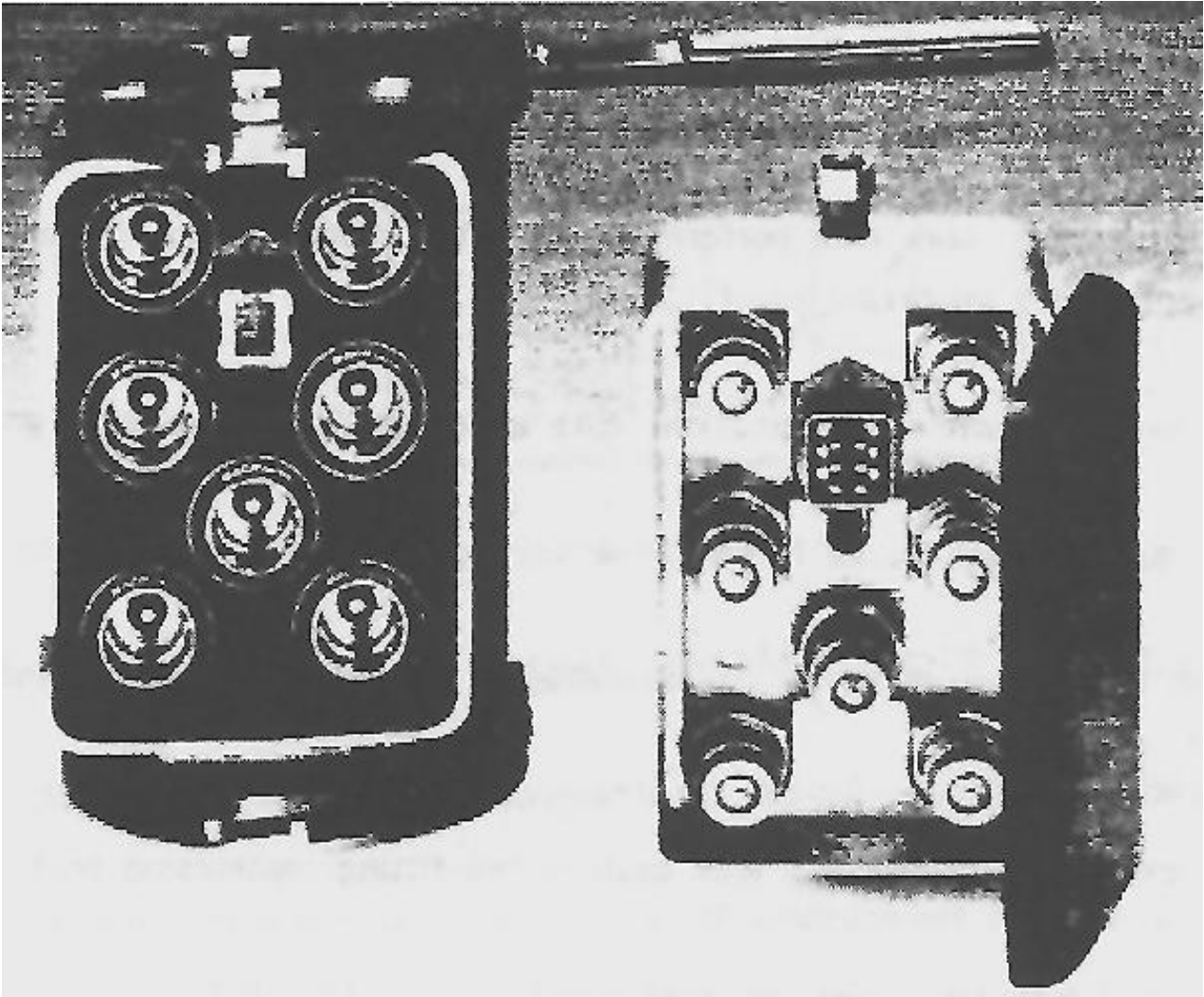

### ***MULTI-COUPLER SYSTEM***

19 In the above figure, the quick couplings used conform to ISO standard 7241 series A.

20 It allows simultaneous connection of all hydraulic and electrical lines and offers many advantages:

- (1) Service pressure up to 250 bar***
- (2) Compact, lightweight, multi-coupler with a strong construction***
- (3) Simple, effective and fast connection even under severe service conditions***
- (4) Housing and cover for total dust and moisture protection and long service life***
- (5) Safe connection, even under pressure***
- (6) Impossible to connect incorrectly***
- (7) Developed with the user for the user***
- (8) Compatible with any equipment already fitted with standard ISO A quick***

## **COMPONENTS FOR EVALUATION 1993.**

### Couplings

- 21 This multi-coupler system may also be used for materials handling and public works equipment, machine tools and other industrial equipment.
- 22 That is just one point to think about, remember that there are 64 flight cells, which must be able to function by more than just one option, there must be at least three different options of operation of these flight cells.
- 23 So think upon it!

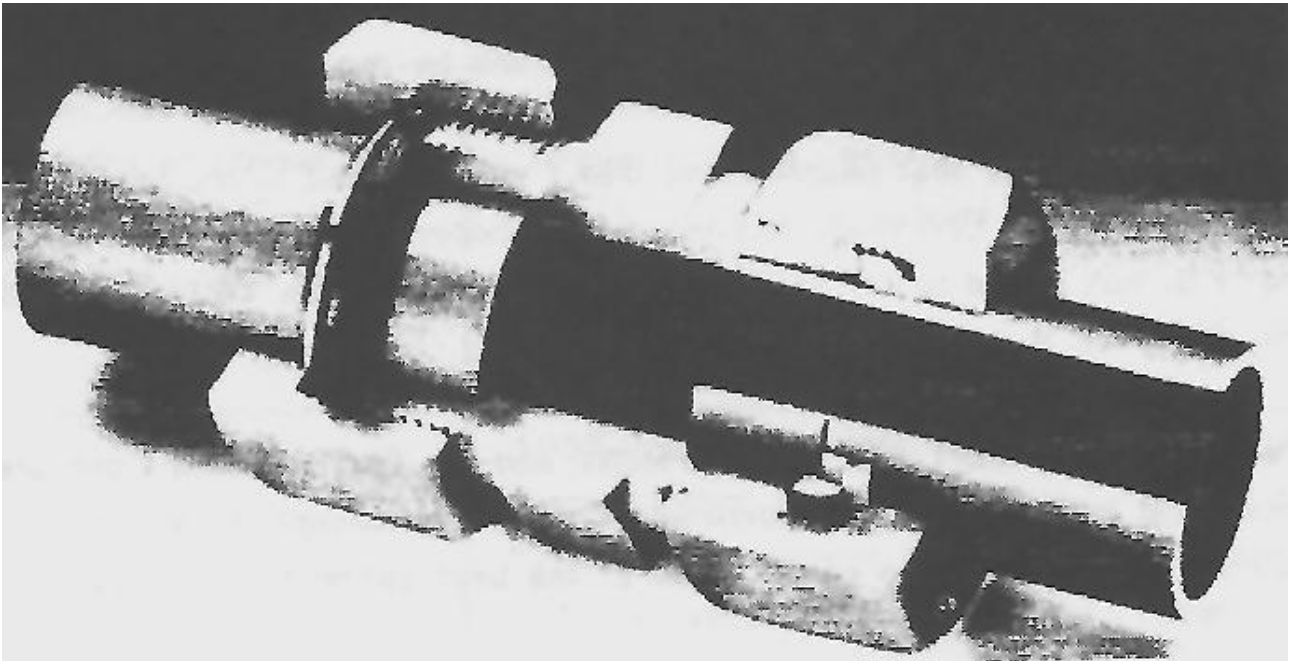

### ***EO-2 DRY TECHNOLOGY.***

- 24 EO-2 is a new generation of leak free fittings, and forms part of a “Searl’s *Dry Technology*” programme for the *INVERSE-G-VEHICLE*, for a safe, clean, leak free sealing even under the most severe conditions.
- 25 Conforming to DIN 2353 standard, the EO-2 bite type fitting has been completely re-engineered to feature vastly simplified assembly characteristics.
- 26 EO-2 incorporates soft sealing for secure, leak free performance, the number of parts has been reduced for easier handling, and stocking, which will be very important point.
- 27 Simple one stage assembly to block, without lubrication, cuts assembly time, two very good points to consider.
- 28 Assembly by torque is possible, as is full assembly by electrohydraulic tooling.
- 29 The nitrile rubber bonded seal on the ferrule gives all the advantages of soft sealed joints, including tolerance of surface imperfections, dirt, misalignment, etc.

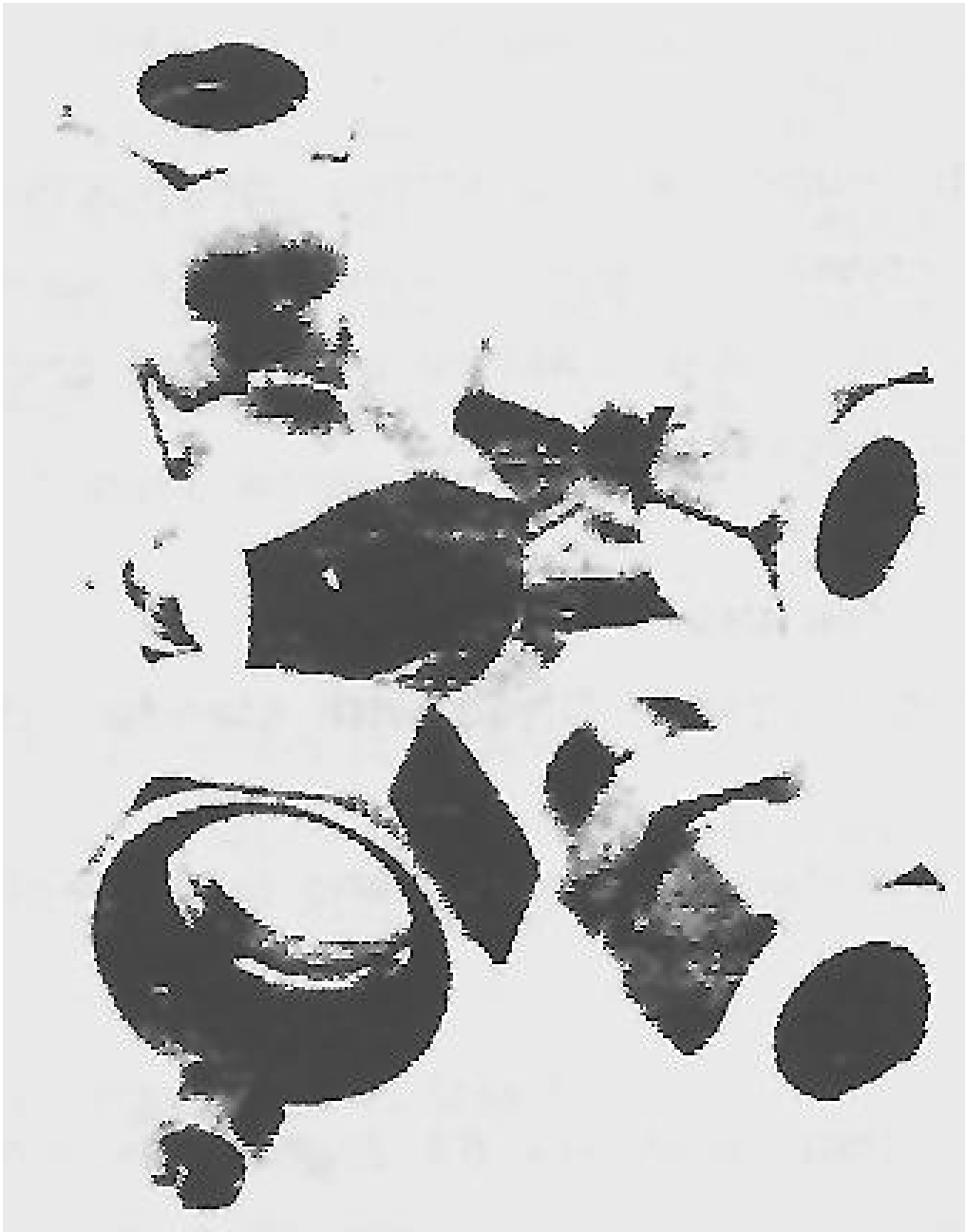

**EO-2 A new generation of fittings with soft sealing, allowing leaks to be prevented more effectively than ever before**

- 30 The sealing lip blocks the only possible leak path in the fitting, optimising performance.
- 31 An integral bite ring gives the mechanical joint onto the tube.
- 32 To make the use of EO-2 even easier, the soft seal ferrule is factory fitted into the body nut to operate as a single unit, making it impossible to lose ferrules or assemble them the wrong way round.
- 33 Another unique advantage is that the nut stays where it is placed on the tube, instead of sliding to the lowest point or off the end, as no doubt that many of my readers can well appreciate the ruddy nuisance it is when you are trying to fit a pipe

## **COMPONENTS FOR EVALUATION 1993.**

In a hurry, to find that the nut is not where you want it.

34 I know what you say even if it is only mentally, when you are up 50 or more feet in the air, and that nut is lying on the floor.

35 You need not be ashamed of that fact, there are many more members of the same Club, you are not alone.

36

EO-2 can solve problems for applications where assembly difficulties have been experienced, boy they can state that again, or leaks have led to costly rework, cleaning up, or warranty charges.

37 FAULT-TOLERANT CMOS MULTIPLEXERS OFFER "BEST BUY" PROTECTION

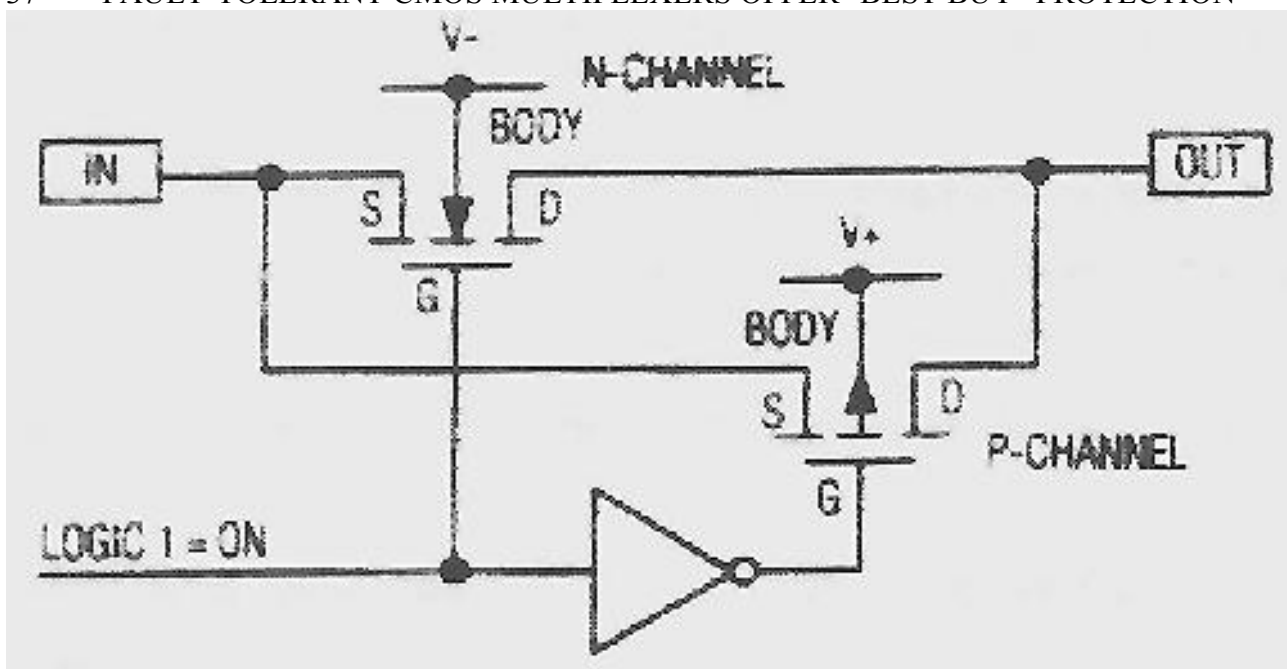

***THE TRADITIONAL CMOS ANALOG SWITCH IS A TRANSMISSION GATE***

38 All analog multiplexes act as the solid-state equivalents of digitally controlled rotary switches.

39 However, multiplexes at the interface between an electronic system and its environment have an additional function - they act as insurance policies against malfunction and damage.

40 As a designer, I may control the system, but input multiplexes contend with everything outside the system - poor installation, careless operators, and electrical noise.

41 They must operate correctly in the presence of ground loops, electrical interference from motors and engines, and unintentional inputs such as 240 VAC.

42 In my following discussion, a particular design (the serial MOSFET switch) comes to mind, as one of the devices which emerges as the most economical choice in

## COMPONENTS FOR EVALUATION 1993.

overcoming these problems.

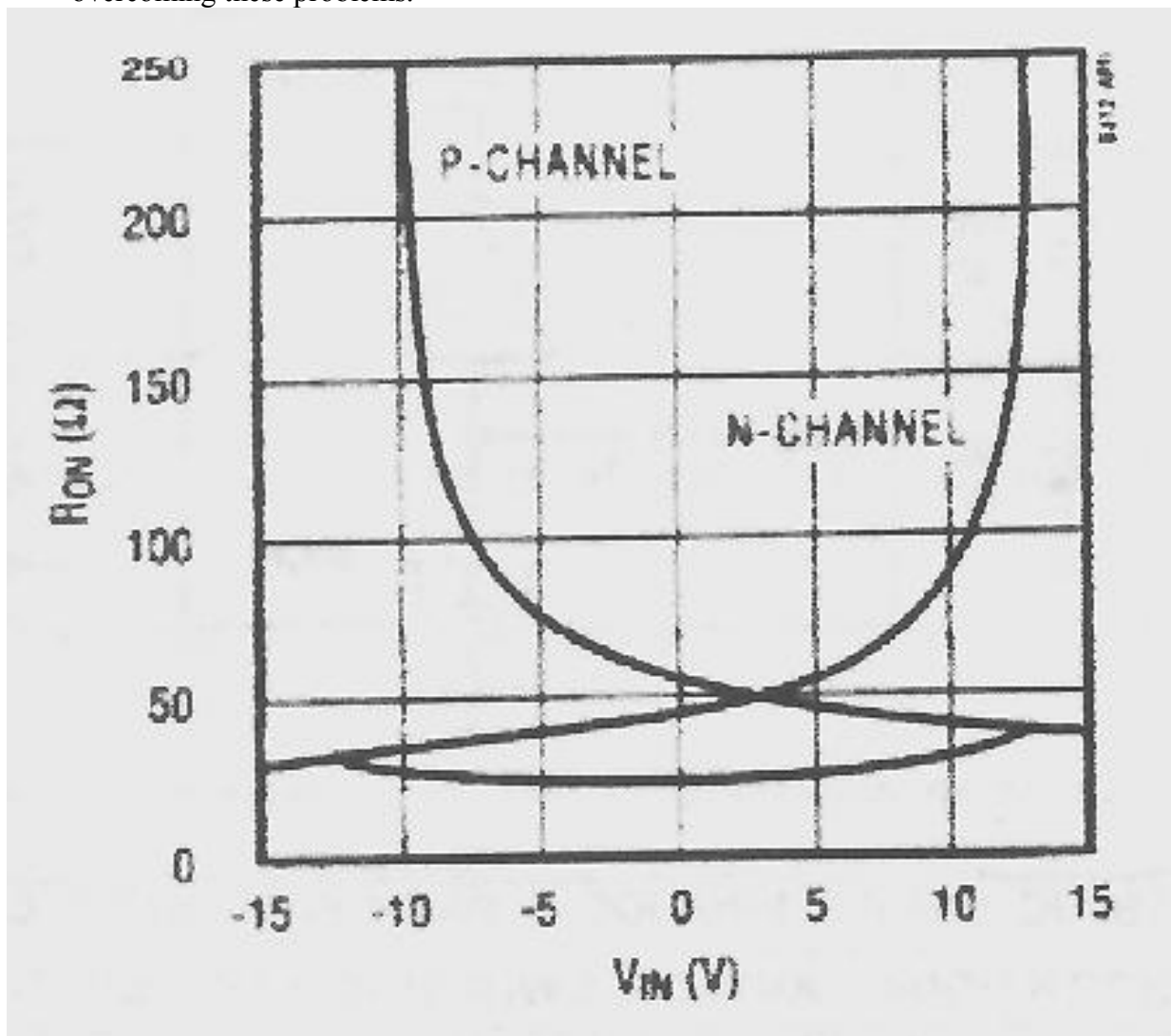

**WHOSE ON-RESISTANCE VS. SIGNAL VOLTAGE CHARACTERISTIC EXHIBITS A DOUBLE HUMP AS SHOWN**

- 43 Other designs offer over voltage protection alone, but only, at least to my knowledge, the serial-MOSFET approach combines overvoltage and fault tolerance without the need for external components.
- 44 The switches in common multiplexers have been designed the same way for nearly twenty years: each consists of an n-channel and p-channel MOSFET connected in parallel on a SILICON substrate, and driven with opposite-polarity gate-drive voltages as shown in my figure on page 11.
- 45 This connection provides a symmetrical signal path through the parallel source-to-drain resistances, producing a characteristic double hump in the curve of on-resistance vs. input voltage as shown in my second figure above.
- 46 Many designs minimise this effect by driving the body connection of the n-channel MOSFET with signal voltage.



## COMPONENTS FOR EVALUATION 1993.

- 47 The presence of each device polarity guarantees that at least one of the two MOSFETs will conduct for any input voltage between the supply rails.
- 48 Thus, the multiplexers can handle any signal level that falls between the rails.
- 49 A multiplexer switch ceases to be a switch, however, when signal voltage exceeds either supply rail.
- 50 Each switch includes two parasitic diodes, intrinsic to the MOSFET source and drain structures, which provide current paths to the rails, at this precise time.
- 51 I cannot put in the figure that I want, the drawing is far too large to scan in here, so hopefully I can find a way of reducing the size of it and add it at the back of the book, if I don't forget it.
- 52 Both diodes are reverse-biased during normal operation, but any signal excursion beyond the rails applies forward bias to one of the diodes, clamping the signal at 600 mV beyond the rail.
- 53 Because the diodes are present when power is removed, they also clamp (at  $\pm 600$  mV) when the rails are at zero volts.
- 54 Parasitic diodes provide a useful clamping function, but they also introduce problems.
- 55 Excessive current in the diodes can cause overheating and damage in the signal source as well as the multiplexer (figure 3)

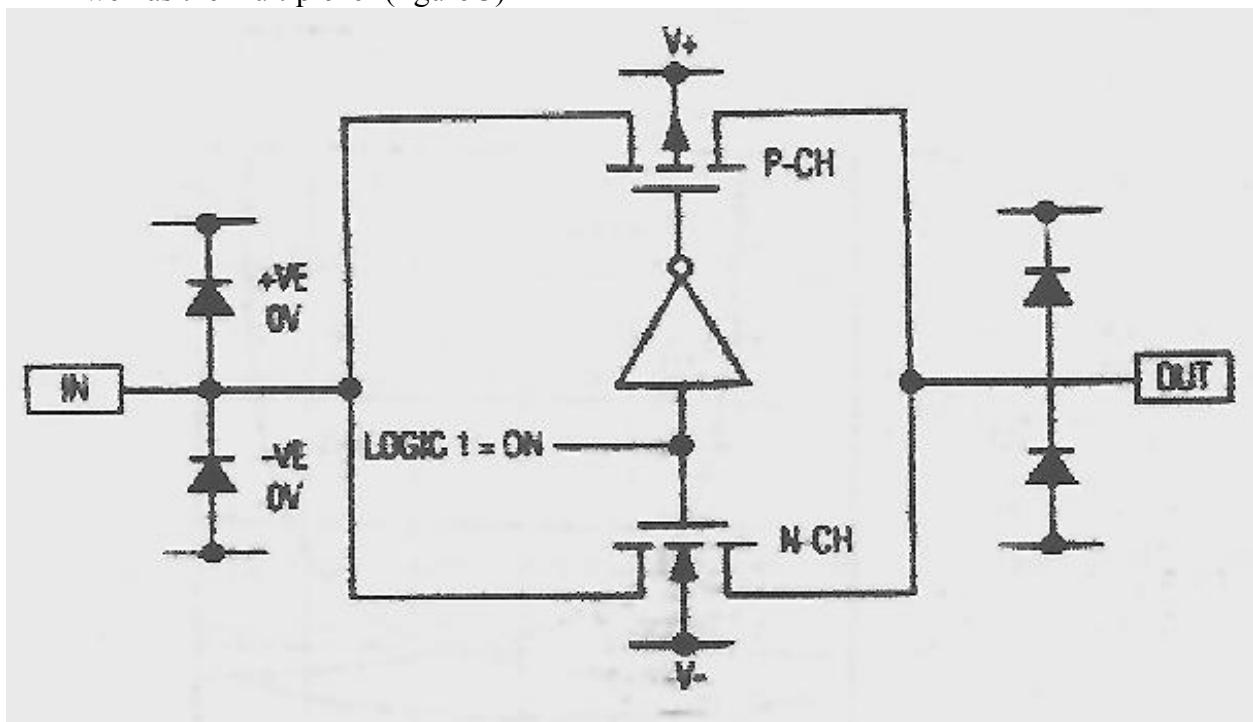
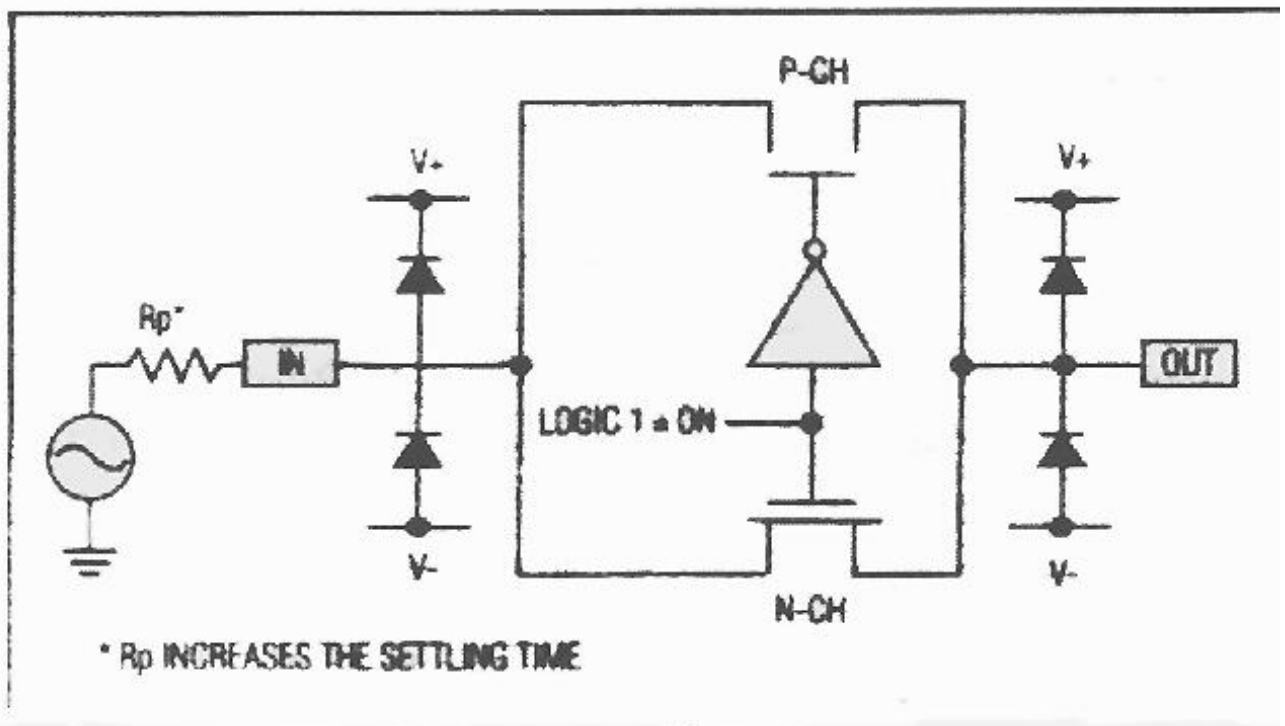

**FIGURE 3. PARASITIC DIODES PROVIDE A PATH FOR FAULT CURRENT WHEN A CONVENTIONAL ANALOG SWITCH IS EXPOSED TO OVERVOLTAGE**



## COMPONENTS FOR EVALUATION 1993.

- 56 Somewhat lower levels of current (below that of overheating and damage) can still cause latch up in the multiplexer.
- 57 And once it crosses a diode junction, the fault current becomes a flow of injected minority carriers that "spray" into the SILICON substrate.
- 58 Collected by other switching devices, this current can induce an error voltage in every channel.
- 59 Turning on parasitic diode clamps the multiplexer output to one supply rail - an action that can damage external circuits connected to that output.
- 60 The cause of damage may not be obvious, but an output transient (to the rail) caused by momentary over voltage at the multiplexer can destroy an A/D converter's input, or cause differential overload and long settling times in an op amp.
- 61 Several design measures offer protection for a CMOS multiplexer and its associated external circuits.
- 62 These measures include connecting a resistor in series with each channel input, connecting diode-resistor networks to control the fault effects, and choosing a multiplexer whose architecture and process technology provide fault-tolerant properties.



**FIGURE 4.** Adding a series resistor to the switch of figure 4 limits fault current, But it also adds to the switch resistance and lengthens settling time

- 63 The simplest form of protection adds series resistors that work in conjunction with the internal protection diodes (Figure 4)

## **COMPONENTS FOR EVALUATION 1993.**

- 64 The resistor values are critical because they present a trade-off: larger values give more protection but introduce greater signal errors.
- 65 Leakage current into the multiplexer also flows through the series resistors, causing an error voltage that worsens with temperature (the leakage doubles for each 8°C increase above ambient).
- 66 Lowering the resistor values can reduce error to an acceptable level, but the lower value may allow too much diode current, threatening latch-up in the multiplexer.
- 67 As a rule, unless otherwise specified in the data sheet section on absolute maximum ratings, you should limit the diode current to 20 mA continuous or 40 mA peaks.
- 68 Low leakage currents can offset this drawback of large protection resistors.
- 69 New, ultra-low-leakage multiplexers such as (MAX328 and MAX329) have extended the design limits for series-resistor protection over those for earlier-generation multiplexers.
- 70 The new devices low leakage ( $\pm 1$  pA at 25°C;  $\pm 20$  nA at 125°C) allows very high-valued protection resistors.
- 71 Resistors of 150 k $\Omega$ , for example, admit fault currents of only 1 mA while withstanding  $\pm 150$  V input.
- 72 At  $\pm 1500$  V, they admit fault currents of only  $\pm 10$  mA.
- 73 The resistors produce only  $\pm 3$  mV of additional error at 125°C.
- 74 Note that in the next figure at  $\pm 1500$  V protection resistors require 15 W ratings for continuous duty.
- 75 However, in most applications you can scale this thermal rating considerably because the over voltage has a much lower duty cycle.
- 76 External resistors thus offer flexibility - you can choose different resistor values for different channels in the same device, and scale their power ratings as required.
- 77 Integrated resistors, on the other hand, are constrained by their package power rating; this rating may limit the number of channels that can withstand over voltage at the same time.
- 78 The series-resistor approach protects the multiplexer, but it does not prevent corruption of signals in the selected channel.
- 79 These signals are at the mercy of over voltage in any of the unselected channels.
- 80 But the direct cause isn't overvoltage ; it's fault current (the injected minority carriers mentioned earlier) flowing into the substrate via one or more protection diodes.

**COMPONENTS FOR EVALUATION 1993.**

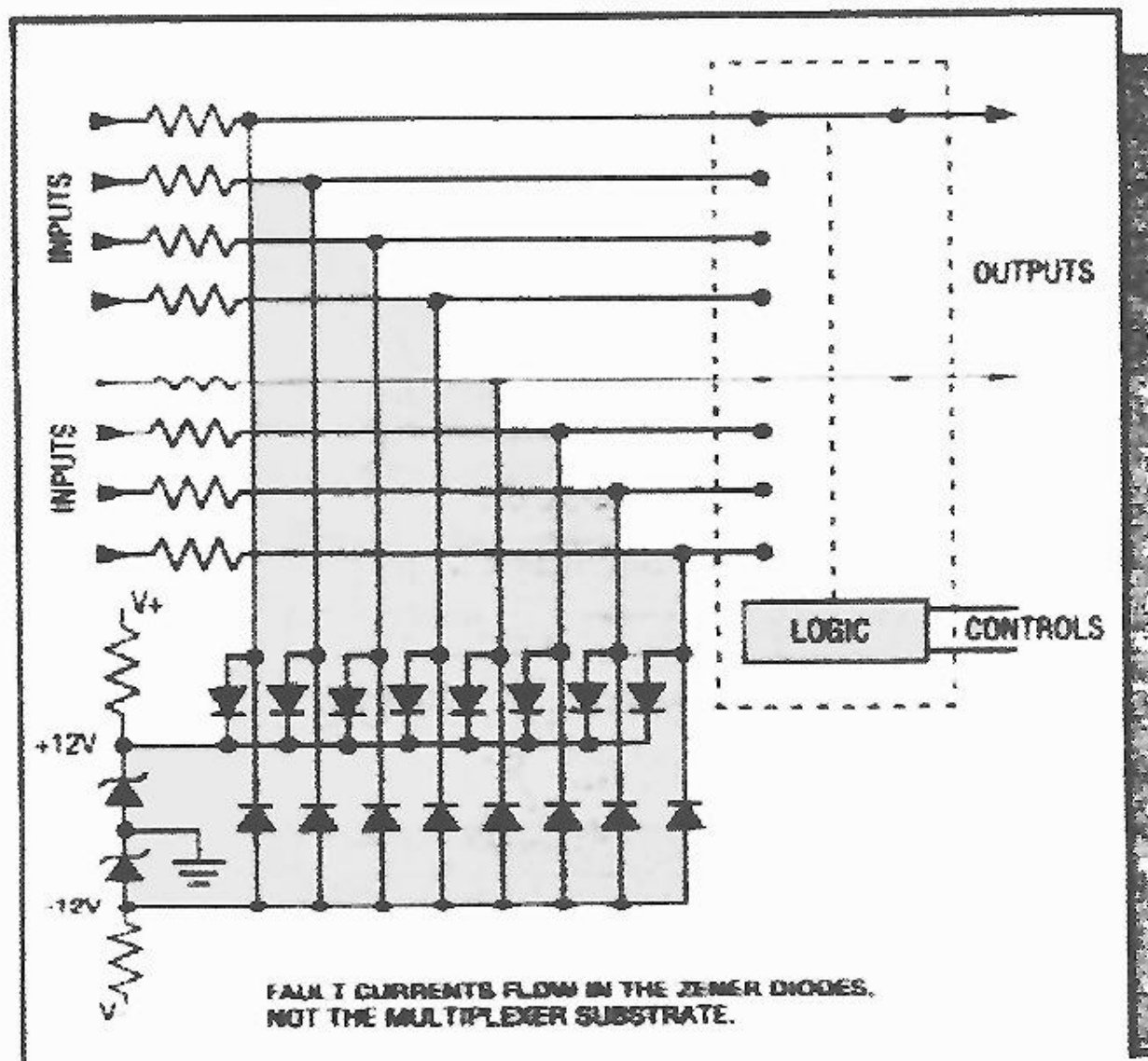

**FIGURE 5** *Fault protections for a conventional multiplexer entails current limiting resistors. Two zener diodes for a bipolar clamp voltage network and dual clamp diodes for each channel.*

- 81 Eliminate that substrate current and you eliminate the gross signal errors.
- 82 One way to handle the fault current is to divert it into an external network (FIGURE 5 above).
- 83 Two zener diodes produce  $\pm 12$  V clamp levels, centred within the multiplexer's  $\pm 15$  V supply rails.
- 84 Then, instead of flowing through an internal protective diode, the fault current due to over voltage on any channel flows through one of the two external protection diodes for that channel.
- 85 Though it offers excellent protection, this technique requires a large number of

## COMPONENTS FOR EVALUATION 1993.

external components.

- 86 And, the external diodes produce additional leakage current that precludes use of the high-valued series resistors discussed earlier.
- 87 The external components represent extra board space, not to mention the cost of purchase, test, through-hole assembly, and inventory.
- 88 I think that a better solution is to integrate this protection with the multiplexer, on a single chip.
- 89 Fault-tolerant multiplexer require no external components, yet are capable of withstanding high levels of over voltage without corresponding high levels of fault current.
- 90 They achieve this protection with an internal design that is quite different from that of conventional multiplexers.
- 91 Each switch in a fault-tolerant multiplexer is actually a series connection of three MOSFETs, in order n-channel/p-channel/n-channel (FIGURE 6a) below.

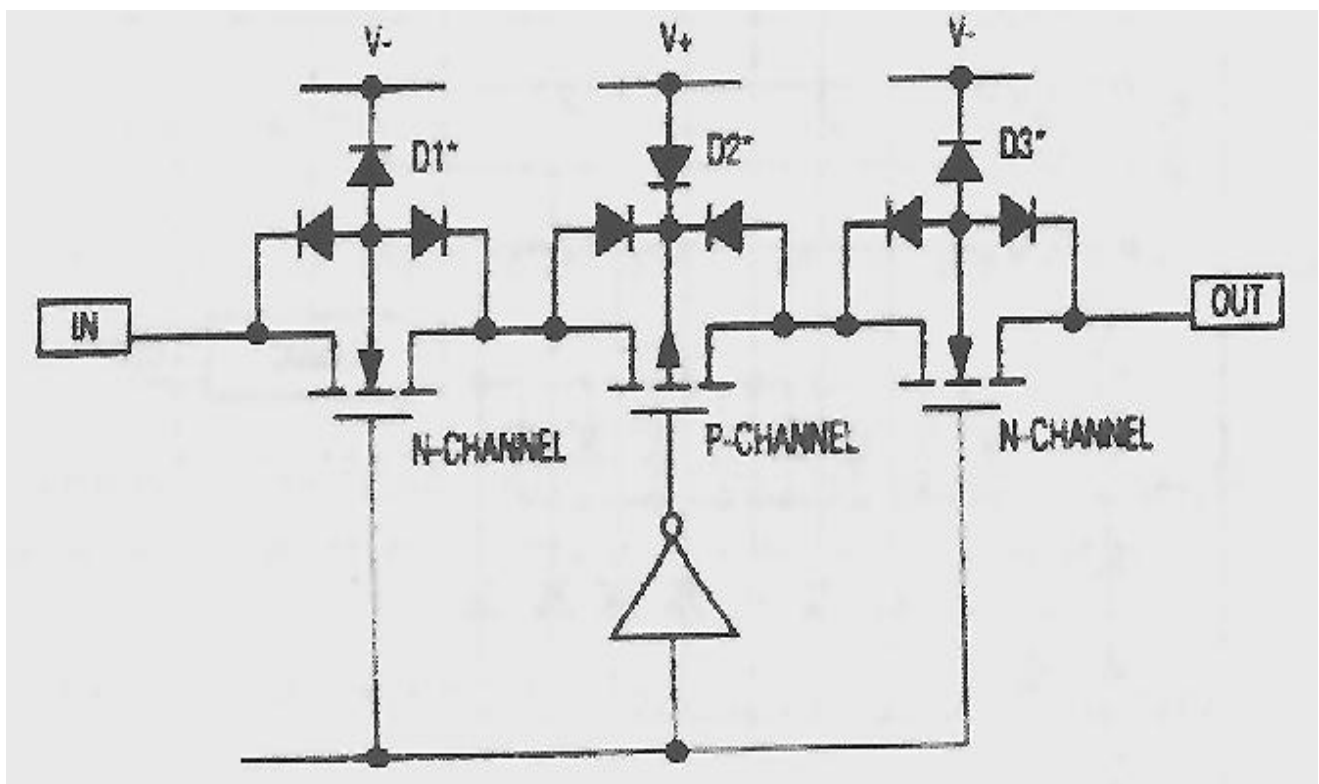
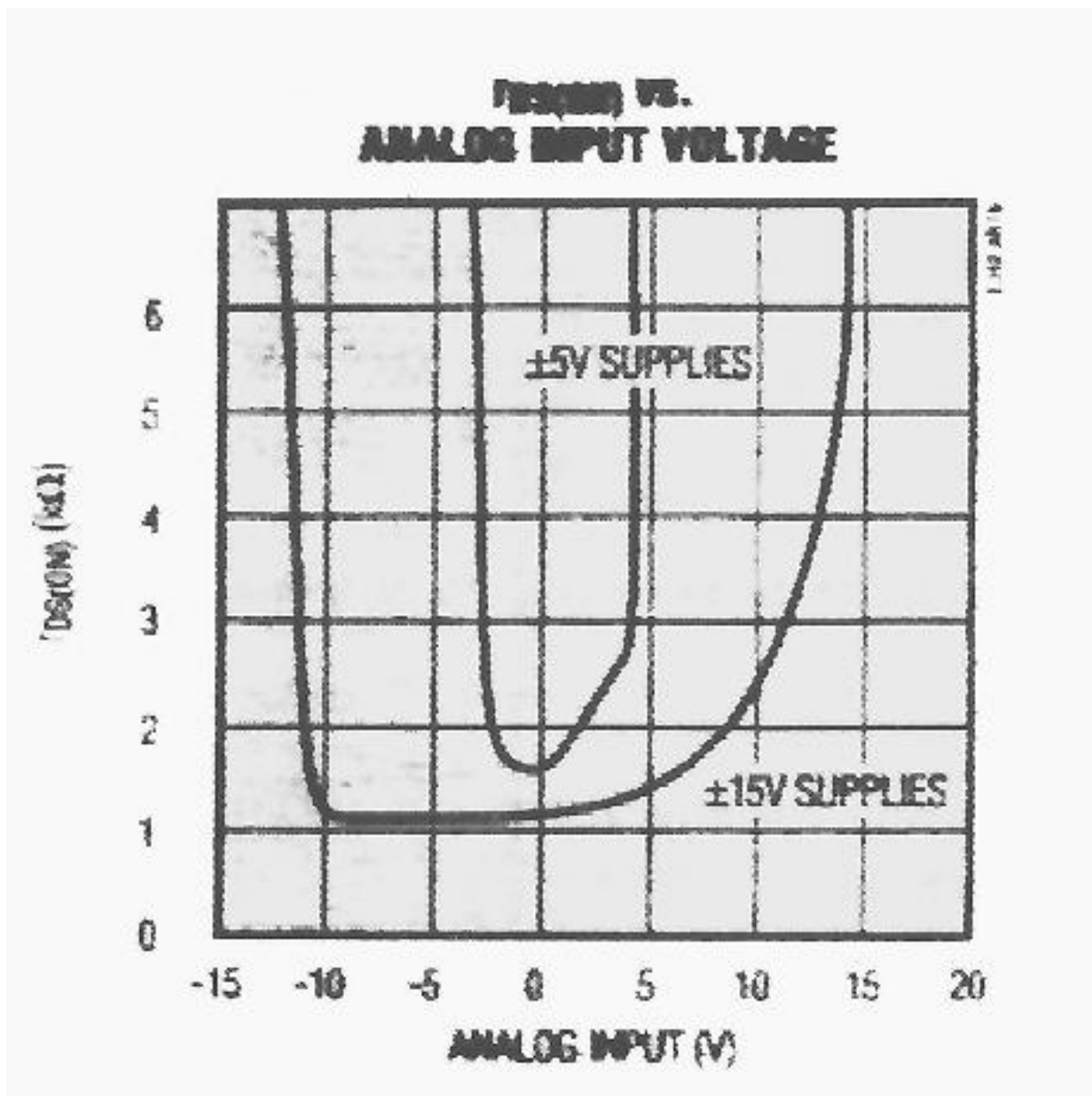

**FIGURE 6a.** The 3 MOSFET switch element of a fault-tolerant multiplexer

- 92 Internally generated drive voltages turn the switch on by simultaneously driving the n-channel gates to the positive rail and the p-channel gate to the negative rail.
- 93 The switch then remains on for as long as the analogue signal (which modulates the gate-source voltages) remains within limits set by the n- and p-channel gate-source thresholds.

## COMPONENTS FOR EVALUATION 1993.

- 94 Typical gate-source thresholds are 1.5 V for n-channel devices and 3 V for p-channel devices.
- 95 Therefore, with  $\pm 15$  V supplies the thresholds confine a multiplexer's input signals to the range - 12 V to 13.5 V.
- 96 Because one of the three MOSFETs in a switch begins to turn off as the signal exceeds either limit, the switch on-resistance versus input voltage assumes a characteristic "bathtub-shaped" curve FIGURE 6b, below.
- 97 The resulting high impedance in the off state is very convenient: the switch is off, blocking the over voltage, and fault current is virtually zeroed.



**FIGURE 6B.** Has an on resistance characteristic shaped like a bathtub.



**COMPONENTS FOR EVALUATION 1993.**

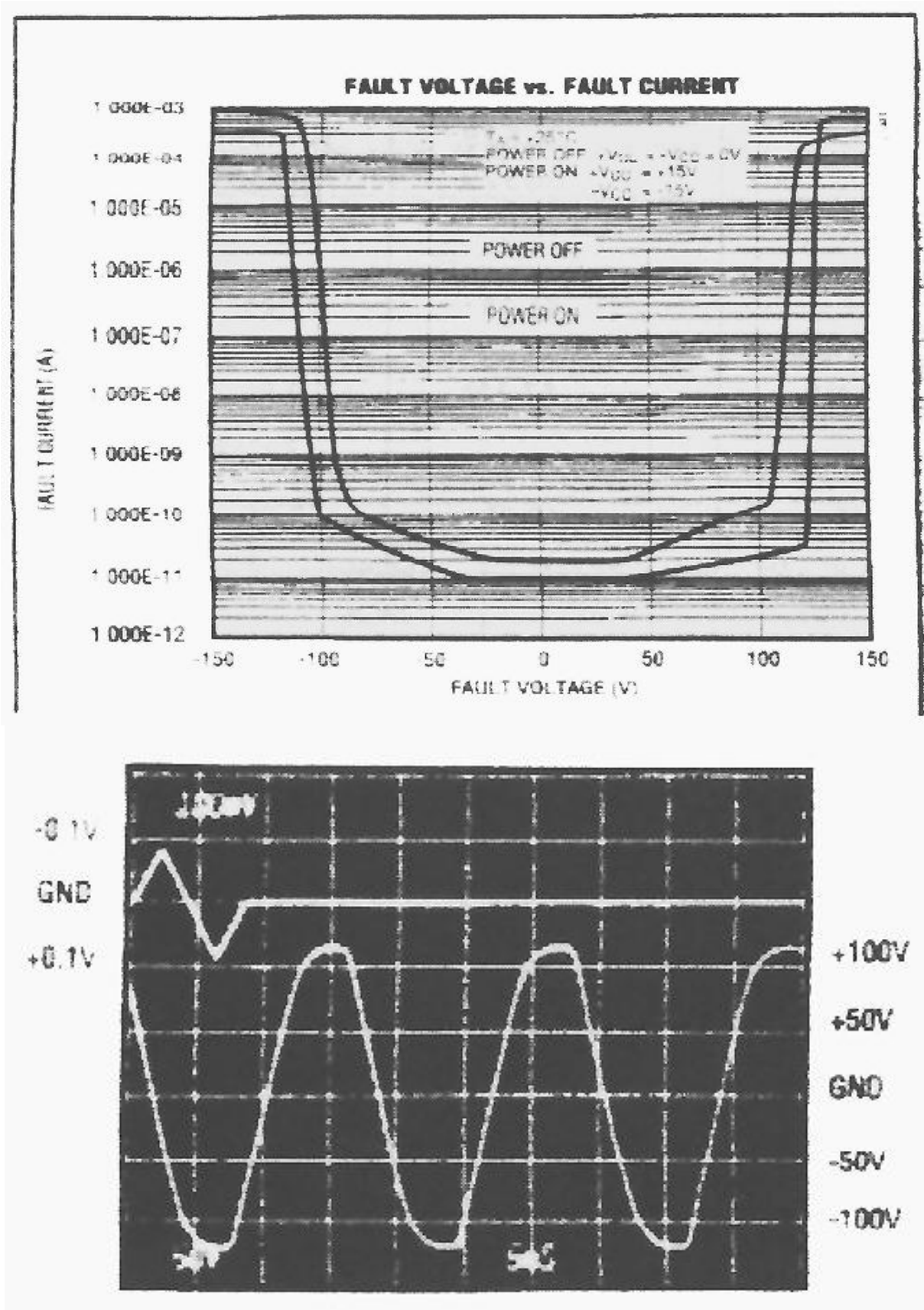

**FIGURE 7. Report on next page.**



## **COMPONENTS FOR EVALUATION 1993.**

FIGURE 7. The onset of avalanche (fault) current in a MAX388 multiplexer defines a Fault-tolerant region of approximately  $\pm 100$  V.

A 0 V signal in the selected channel (top trace) is unaffected by  $\pm 100$  V applied to an off channel.

---

- 98 Substrate (fault) current flows only as a result of avalanche, which occurs when the over voltage exceeds a limit, set by the MOSFET's geometry and doping levels.
- 99 Below the avalanche limit, signals in the selected channel remain unaffected because the over voltage produces no substrate current
- 100 The series-connected switch also turns off when power is removed.
- 101 This behaviour simplifies the design of redundant systems; because multiplexers connect to common signal lines can be powered down without loading the lines.
- 102 Dr. Edwards please note that all these wonderful things quoted here were conceived in the world of fantasy, but their birth was delivered in the world of reality.
- 103 Yes Dr. Edwards I am here to teach you as well as every one else, so please listen very careful to what I state, and take note.
- 104 To my knowledge, Maxim offers several series-structure multiplexers.
- 105 The MAX358 and MAX359 devices (1-of-8 and dual 1-of-4) withstand over voltages to  $\pm 35$  V, and the MAX378 and MAX379 are similar devices that withstand over voltages to  $\pm 75$  V.
- 106 MAX368 and MAX369 add latched address inputs to the basic 35 V tolerant models, and the new MAX388 and MAX389 are latched models that withstand  $\pm 100$  V.
- 107 The non-latched devices are pin compatible with industry-standard multiplexers DG508/509: the latched devices are pin compatible with the latched models DG528/529.
- 108 As shown earlier in FIGURE 5, conventional multiplexers such as the DG508/509 require numerous external components to duplicate the fault-tolerant capabilities mentioned in this report.
- 109 MAX3XX devices not only save the cost and board area associated with external components, they offer capabilities not available in discrete-component circuits.
- 110 MAX3XX devices always turn off when over voltage is applied, but the switches of FIGURE 5, remain on in the presence of over voltage whether power is applied or not; this is only a tiny part of my thinking process for this development work.

I never knock NASA product, in effort to push mine - that is not cricket!

## COMPONENTS FOR EVALUATION 1993.

111 The following (TABLE 1) shows the cost advantages of fault-tolerant multiplexers vs. the non-protected DG508/509 alternatives.

**TABLE 1. NONLATCHED MULTIPLEXERS**

	DG528/ DG529	MAX368/ MAX369	MAX388/ MAX389
<b>Inherent O/V protection</b>	<b>NONE</b>	<b>± 35 V</b>	<b>± 100 V</b>
<b>Resale cost, 1 K pcs</b>	<b>\$1.78</b>	<b>\$3.25</b>	<b>\$3.75</b>
<b>External component cost And assembly</b>	<b>\$2.15*</b>	<b>0.00</b>	<b>0.00</b>
<b>TOTAL SYSTEM COST</b>	<b>\$3.93</b>	<b>\$3.25</b>	<b>\$3.75</b>

\* = 28 External components (x) .03 (+) 28 (x) 2 leads (x) .007

### *The cost of the:*

**(1) 10 resistors**

**(2) 16 diodes**

**(3) 2 zeners**

112 In FIGURE 5, is about \$0.92, based on the purchases of 1 K pieces or more.

113 Plated-through holes are about \$0.007 each, and the assembly cost for axial-leaded parts is about \$0.03 per component.

114 The resulting total for multi-component protection exceeds that of the simpler, single IC protection offered by Maxim.

115 External components also require five times more board area than the IC alone.

116 The cost in FIGURE 5's, circuit is even greater if you consider the cost of troubleshooting, reliability effects, and other hidden expenses.

117 All of TABLE 1's ICs have an Absolute Maximum rating of 44 V between the V+ and V- terminals, but increasing die sizes from left to right necessarily escalate the 1 K-pc prices.

118 I had to leave out what would have been FIGURE 2, as part of it was far too large to include there. I have now reduced its size to half; it means that the contents do not stand out as clear as planned.

119 I hope that you will obtain enough **FACTS** from it to understand what it shows.

LOS-1.

DATE: 10<sup>th</sup> July 1968.  
EDITION: First.

1 H																	2 He									
3 Li	4 Be											5 B	6 C	7 N	8 O	9 F	10 Ne									
11 Na	12 Mg											13 Al	14 Si	15 P	16 S	17 Cl	18 Ar									
19 K	20 Ca	21 Sc	22 Ti	23 V	24 Cr	25 Mn	26 Fe	27 Co	28 Ni	29 Cu	30 Zn	31 Ga	32 Ge	33 As	34 Se	35 Br	36 Kr									
37 Rb	38 Sr	39 Y	40 Zr	41 Nb	42 Mo	43 Tc	44 Ru	45 Rh	46 Pd	47 Ag	48 Cd	49 In	50 Sn	51 Sb	52 Te	53 I	54 Xe									
55 Cs	56 Ba											72 Hf	73 Ta	74 W	75 Re	76 Os	77 Ir	78 Pt	79 Au	80 Hg	81 Tl	82 Pb	83 Bi	84 Po	85 At	86 Rn
87 Fr	88 Ra											104 Rf	105 Db	106 Sg	107 Bh	108 Hs	109 Mt	110 Ds	111 Rg	112 Uub	113 Uut	114 Uuq	115 Uup	116 Uuh	117 Uus	118 Uuo
		57 La	58 Ce	59 Pr	60 Nd	61 Pm	62 Sm	63 Eu	64 Gd	65 Tb	66 Dy	67 Ho	68 Er	69 Tm	70 Yb	71 Lu										
		89 Ac	90 Th	91 Pa	92 U	93 Np	94 Pu	95 Am	96 Cm	97 Bk	98 Cf	99 Es	100 Fm	101 Md	102 No	103 Lr										

*Mortimer-Berkshire-England.*

- LOCATION :** *Headquarters-Mortimer-Berkshire-England.*
- DIVISION :** *Manned Flight.*
- SEMINAR :** *Star Ship Ezekiel MK V Concept.*
- LECTURER :** *John Roy Robert Searl.*
- STATUS :** *Head of R&D Human Studies.*

**Star Ship Ezekiel MK V agreed concept:**

Should be based upon my dreams one and two contents, that is to use the law of the squares in the concept design.

First, let us look at the squares, what are we talking about in reality?

8	30	34	3	5	31
35	1	28	9	26	12
18	17	15	21	27	13
19	20	16	22	10	24
25	11	14	23	36	2
6	32	4	33	7	29

22	88	100	7	13	91
103	1	82	25	76	34
52	49	43	61	79	37
55	58	46	64	28	70
73	31	40	67	106	4
16	94	10	97	18	85

40	150	170	15	25	155
175	5	140	45	130	60
90	85	75	105	135	65
95	100	80	110	50	120
125	55	70	115	180	10
30	160	20	165	35	145

37	147	167	12	22	152
172	2	137	42	127	57
87	82	72	102	132	62
92	97	77	107	47	117
122	52	67	112	177	7
27	157	17	162	32	142

You should see that I am using square six; you can also see that it is constructed from 36 cells, each cell holds a value.

I use square six for flight requirements, why do I use square six and not some other form of mathematics.

Son that is a good question, you see I have no knowledge on mathematics, as I had no formal education, like you because I have no normal hearing.

It was impossible for me to understand what my teacher was saying, I did nether the less understood what her hand was saying to my checks of my bum that she was going to make it red and hot – and she did to that issue there is no argument.

They fail to try to find out why a child cannot learn, do not question if they are deaf – they assume they hear.

Have selected the square that you are going to employ you then have to select the elements, which is important issue that the dream one say go square four, which is absolutely correct but only for land base use, unfortunate not powerful enough for flight work. Looking at dream one, I cannot help seeing that always there are eight squares, not only that I am always in square 2.

This is where you actually use your brain, **WHY?**

Because that is what it is actually for, to be used, and I had no option but to use mine, that is why I conceived the Searl Effect concept.

Here was a dream, which kept re-occurring surely, there must be some logic reason for it. Now if we take two away from eight we get six, you agree, strange that dream run for six years.

That two covers many issues that are actually involved, I shall be involved in two completely different fields of technology:

**1. Land base energy requirements.**

**2. Flight base requirements.**

That dream also stating that you have to use four layers, three of which must be true elements plus one, which is not a true element but a molecule structure.

A concept is being born, and it is from such a chart, which as displayed at the heading of this document that I used within this technology.

Now I am standing in square two: there are two states involved here up and return back, thus I accept that I shall be involved in two different domains.

One, which is down representing ground systems; and other one up; representing flight. Thus cell two and cell four plus cell eight are the key issues as cell three you have to hop over and not into it.

I multiply these together and obtain:

$$2 \times 4 = 8 \quad 8 \times 8 = 64$$

Therefore, eight must have some importance, and likewise 64 – this is where my brain does the thinking and not me.

You can guess that eight relates to the periodic table, the 64 relates to the flight side, just for this moment I shall concentrate upon that issue eight.

It relates to the electrons, which I have already explained within this book the behaviour of the atom in its construct of the electrons.

That the four layers move from the outside layer the density goes up as you go towards the centre, except for the molecule layer, which controls the flow of electrons from the rare earth material.

Slowly a concept for research and study is in the development state

With all new idea, it is a case of probing in the dark until some light appears, as it will do if you probe deep enough, as I had to do.

At first, it looks impossible and often it is only a small issue to be corrected then its all go.

Dream one state there are two prime states in the universe.

1. **Positive and negative**
2. **Electrons and positrons**
3. **Magnetic north and magnetic south**
4. **Stationary plates and moving parts the roller s**
5. **Conductors and insulators**
6. **Superconductivity and non superconductivity**
7. **Yes and no**
8. **Left and right**
9. **Hot and cold**
10. **Particle and wave**
11. **Male and female**
12. **Current and magnetism**



These are all important issues, because they are all part of reality, and my world is reality without question.

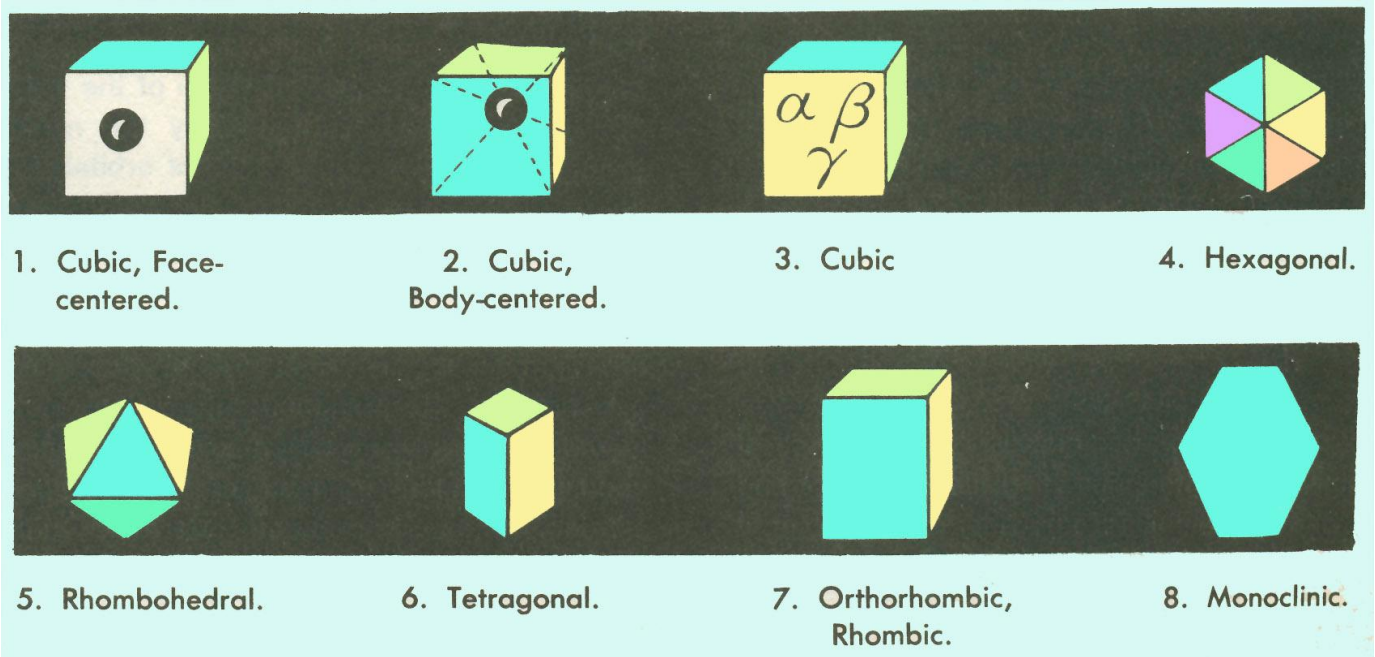

**Here are eight conventional diagrams of crystals forms.**

Which is strange that this hopscotch patch had its system based on eight squares, in the following manner; from bottom to top?

Squares one, two and three in a vertical line then square four and five in horizontal mode followed by square six in the vertical mode ending with square seven and eight in the horizontal mode.

Square one is outside of the function as it represents that level one of all squares structures is its DNA upon which that square system is constructed.

Squares are no different to all the animals; a DNA system controls the construction upon how each species or square created by.

Maybe I have given you a bit too much to digest, after all it is my world born into it and have lived it all my life, therefore, to me it is easy for me to follow, as a yellow brick road would be.

It is an old saying when they is something unknown to be explain it is wiser to give it in small bite at a time so that it may be digested slowly by those who wish to learn and understand, agree most people can learn the problem remains will they understand that which they have learnt.



1	2	3	4	5	6	7	8	9	10
Atomic No. Z	Element	Sym- bol	Atomic Diameter $10^{-10}$ m	First Ionization Potential V	Chemical Valence	Configura- tion of Valence Electrons	Spectral Term of Ground State	Wavelength of Most Intense Spectral Line $10^{-10}$ m	Atomic No. Z
1	Hydrogen	H	1.58	13.598	1	1s <sup>1</sup>	<sup>2</sup> S <sub>0,1/2</sub>	1215.66	1
2	Helium	He	0.98	24.587	0	(1s <sup>2</sup> )	<sup>1</sup> S <sub>0</sub>	584.33	2
3	Lithium	Li	4.10	5.392	1	2s <sup>1</sup>	<sup>2</sup> S <sub>0,1/2</sub>	6707.85	3
4	Beryllium	Be	2.80	9.322	2	2s <sup>2</sup>	<sup>1</sup> S <sub>0</sub>	2348.61	4
5	Boron	B	2.34	8.298	3	2s <sup>2</sup> 2p <sup>1</sup>	<sup>2</sup> P <sub>0,1/2</sub>	2497.73	5
6	Carbon	C	1.82	11.260	±4, 2	2s <sup>2</sup> 2p <sup>2</sup>	<sup>3</sup> P <sub>0</sub>	1657.01	6
7	Nitrogen	N	1.50	14.534	±3, 5, 2	2s <sup>2</sup> 2p <sup>3</sup>	<sup>4</sup> S <sub>1/2</sub>	1134.98	7
8	Oxygen	O	1.30	13.618	-2	2s <sup>2</sup> 2p <sup>4</sup>	<sup>3</sup> P <sub>2</sub>	1302.19	8
9	Fluorine	F	1.14	17.422	-1	2s <sup>2</sup> 2p <sup>5</sup>	<sup>2</sup> P <sub>1/2</sub>	954.82	9
10	Neon	Ne	1.02	21.564	0	(2s <sup>2</sup> 2p <sup>6</sup> )	<sup>1</sup> S <sub>0</sub>	735.89	10

This is my world of reality, the world of tomorrow's technology, the ***Gyro-Flywheel-High Energy Density-Mechanical-magnetic device*** the ***Searl Effect Generator (S.E.G)*** and the ***Inverse-Gravity-Vehicle (I.G.V)***, you might not yet got it, but you should had done so, except for evil minds whose ignorance and greed have blocked you from having it. Unfortunate there is no more dangerous combination than those who steal in ignorance for personal gain

**TABLE 1:**

***Electronic Properties of individual Atoms:***

***Columns 1 and 10 contain the atom number Z, equal to the number of elementary positive charges borne by the nucleus and also to the number of extra-nuclear electrons in the neutral atom.***

***Column 2 contains the name of the element or atom.***

***Column 3 contains the symbol for the element or atom.***

***Column 4 contains the atomic diameter as an expectation value from quantum mechanical average-energy-of-configuration Hartree-Fock computations for free atoms – atomic data 4, the unit is  $10^{-10}$ m.***

***=0.0000000001 m WOW!***

What do you think about that Flowerbower?

You poor creature of misfortune: that is beyond your brain capabilities to understand because that is reality.

**Column5 contains the ionization potential in volts:  
The ionization energy is the ionization potential multiplied by the elementary charge e, and  
has the same numerical value as the ionization potential when the latter is expressed in  
volts and the former in electron volts:**

$$(1 \text{ eV} \cong 1.60219 \times 10^{-19} \text{ J})$$

**That is:  $1.60219 \times 0.00000000000000000001 \text{ J}$**

How are you coping Flowebower, guess there is a great amount of hot air rushing out of that rear end of yours practice makes perfect ready for YouTube attack again?  
I feel that I should halt here to let you recover from this reading, as there is such a lot to show what I knew so long ago now.

Though I cannot no longer study at the same rate due to lack of hard cash not being available, at least I try to continue to learn about reality, which also includes you.  
This document released by authority of:



**Prof. J. R. R. Searl Head of research and development.  
Manned Flight – human studies.**



*Electric Express Locomotive,  
modelled on the class  
BB10000 of the Société  
Nationale des Chemins de  
Ferrançais (SNCF, or French  
National Railways Co.)  
Finished in green  
This was one of a hundred  
different trains that I used to  
display on special show days  
which were stolen while I  
was on Business in Canada  
by my family and replace to  
be stolen again by then while  
I was away.  
They sold them for next to  
nothing in cash.*

**Cost me £8.00 plus postage and package.**





## **MY MEDICAL KNOWLEDGE 1993.**

**JANUARY 1993**

- 1 **STARSHIP EZEKIEL MK.V.** is designed to have its own hospital, and this also apply to a housing complex upon that design.
- 2 But in 1968, its equipment design was very bulky and heavy, so now 25 years later, what is new that can be use to reduce both the size and weight of that equipment which is needed.
- 3 There is a subject matter upon the human body which is really never spoken about, yet to many it is a hell of a problem, one which I must make allowances for in the design of **STARSHIP EZEKIEL MK.V.** or even a housing complex upon the same structural concept.
- 4 The subject again is sensors, but in this case it is a chemical fibre sensor, which is the subject of this discussion.
- 5 This discussion is based upon a subject matter which one do not talk about at the dinner table, yet it is involved with your dinner one way or another.
- 6 It is a new optical sensor for monitoring bile in the stomach which is not just more accurate than existing techniques, it also works around the clock with little disruption to the patient's daily life.
- 7 Which of cause is great stuff for all of us who suffer from any bile related problems.
- 8 Chemical sensors based on optical fibres are advancing faster in biomedicine than those, which depend on competing technologies.
- 9 And fibre-based chemical sensors are developing more rapidly in biomedicine than in any other field.



**THE COMPLETE BILE SENSOR, WHICH MONITORS BILIRUBIN.**

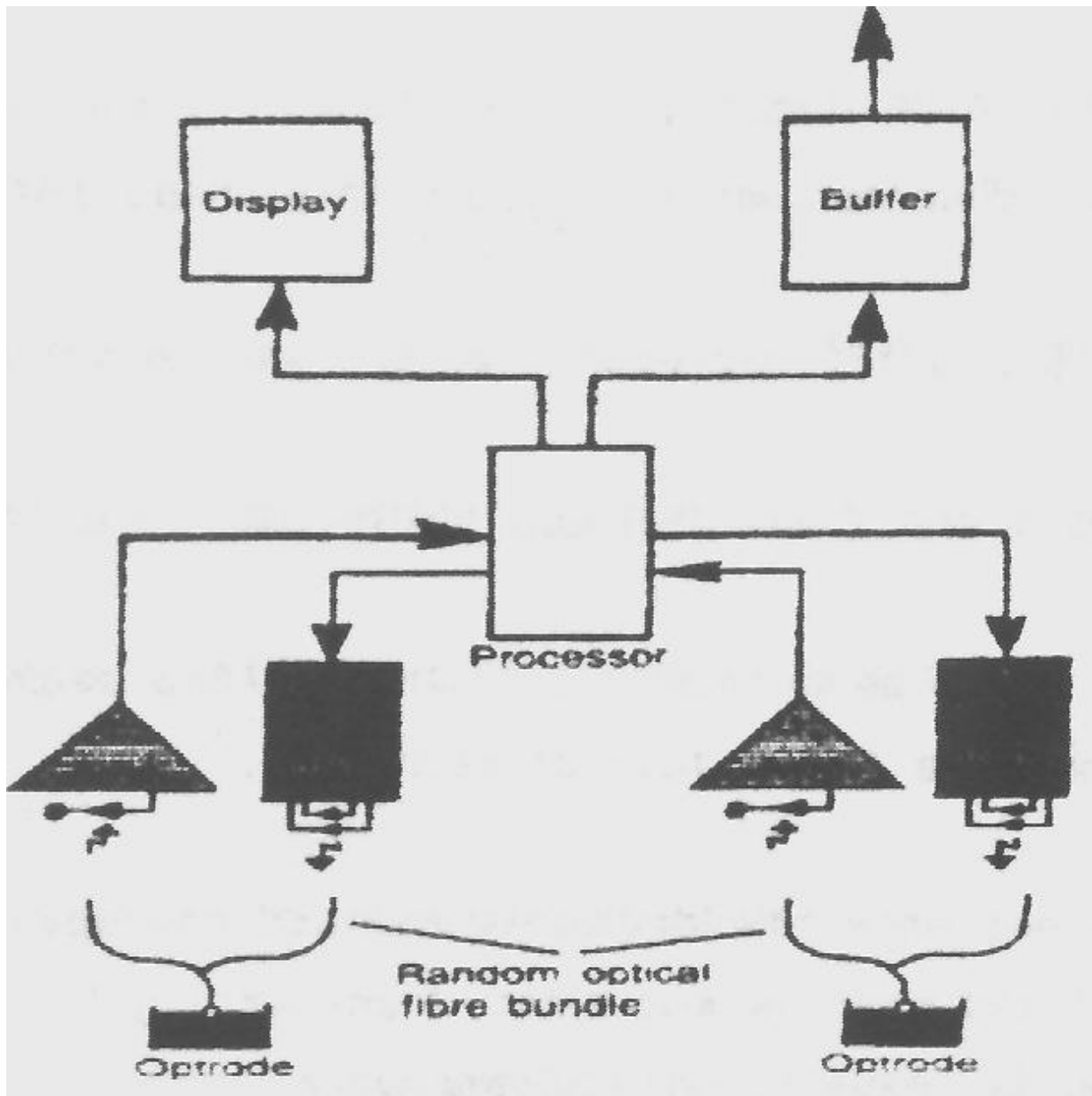

**FIGURE 1b. IT'S OPTOELECTRONIC SYSTEM.**

- 10 I regret that these last two pictures are missing, and I have had to scan them from book 4, which was a photocopy of a photocopy, so as to maintain the same data.
- 11 Wherever I can I have replaced those pictures or drawings with new ones, but some take too long to re-draw them.
- 12 But I hope that it will give some indication of what I am talking about.
- 13 Some scientists might disagree with these two claims which were made by Francesco Baldini, who researches chemical sensors at the Istituto di Ricerca sulle Onde Elettromagnetiche (IROE), Florence, Italy.
- 14 Yes Mr. Anders Heerfordt, Dr. Edwards and Gunnar Sandberg, I bet that none of



## MY MEDICAL KNOWLEDGE 1993.

you knew that I know about that place or that person.

- 15 I also bet that you did not know that I knew the following **FACT** that an IROE sensor, which continuously monitors bile in the oesophagus (for those who do not know what oesophagus refers to, don't worry I am here to tell you, its the canal which extends from the pharynx to the stomach.
- 16 To my knowledge it is about nine inches long, at least that is what I understood back there in 1950.
- 17 You are happy now that you know what I am talking about; you are not, why?
- 18 You are confused as to what the term pharynx relate, o don't worry, I am here to tell you. It's the muscular pouch lined with mucous membrane situated at the back of the mouth.
- 19 It leads into the oesophagus, and also communicates with the nose through the posterior nares, with the ears through the Eustachian tubes, and with the larynx.
- 20 Now you are happy?
- 21 You are not, you don't understand the terms used, well I am sorry I have to leave that for another book, or otherwise the subject of this discussion will never appear within this book.
- 22 This sensor functions by an optical fibre probe inserted through the patient's nose, has just gone on sale.
- 23 At this moment in time, I do not know what it cost.
- 24 Data from the optical transducer or optrode on the end of the fibre are collected in a small battery-powered unit, which is light enough to hang off the patient's belt.
- 25 The sensor takes readings every 4, 8 or 16 seconds, which it displays or records for analysis.
- 26 Buttons on the unit allow the patient to record pain, meals and periods of rest.
- 27 The Italian researchers have just started laboratory tests of a similar sensor to monitor acidity levels in the stomach.
- 28 They are also working on prototypes of fibre sensors that measure the pH of blood, oxygen levels in liquid or gas streams, and others, which, in combination with enzyme reagents, could analyse biological compounds.
- 29 By now you should all know that I am determined to see that every functional unit within the concept of **STARSHIP EZEKIEL MK.V**. or in any similar housing compound will be of the absolute accurate and fast technology that science can offer.

Well you so-call experts what a disgrace you are to your profession with your insults of crap.

## MY MEDICAL KNOWLEDGE 1993.

- 30 Baldini told the Biomedical Optics conference in Hungary that fibre sensors are succeeding in biomedicine because they lack electrical contacts, they are tiny and they come in virtually any shape.
- 31 These qualities, which I appreciate, added to fibre's inherent safety, make the technology "competitive with traditional sensors in both chemical diagnostics and multi-test kits and allow, in some cases, performances which are unique."
- 32 As I stated in 1968, that biomedicine's requirements on **STARSHIP EZEKIEL MK.V**. demand for quality and safety drives innovation by forcing designers to think carefully and to base their sensors on a "thorough spectrophotometric investigation".
- 33 As I stated in 1968, spectrophotometry leads to a "better understanding of chromophores, immobilised or not, which act as an optical transducer and optimise the optrode's optical performance", and this is also what Baldini stated.
- 34 "If the goal of the sensor is in vivo measurements, then particular attention must be paid to the biocompatibility of the optrode."
- 35 There are three basic elements to each sensor :
- (1) **An optoelectronic system**
  - (2) **An optical fibre**
  - (3) **An optrode on the end of the fibre**
- 36 Some optrodes carry chromophores, substances that have unique absorption spectra in the presence of specific chemicals.
- 37 Other optrodes depend on the absorption spectra of target chemicals such as bilirubin, which has an absorption peak at 452 nm.
- 38 Bilirubin is the main pigment in bile, which can cause disease if it enters the stomach from the duodenum.
- 39 You look confused at a much higher level, let me deconfuse you, Duodenum (du-o-de'-num) the first nine or ten inches of the small intestine, from the pyloric opening of the stomach to the jejunum.
- 40 The pancreatic and common bile ducts open into it.
- 41 Now you are happy, you are not, sorry, I must continue with my discussion, or otherwise I will never get it done.
- 42 A typical sensor has two identical fibre channels to monitor a pair of sites simultaneously.
- 43 Two diodes in each channel couple a reference wavelength and a signal

## MY MEDICAL KNOWLEDGE 1993.

Wavelength (matched to the target chemical or the chromophore in the optrode) into one arm of a forked fibre.

- 44 The forked probe is a randomly mixed bundle of polymer optical fibres in a biocompatible black polyurethane catheter.

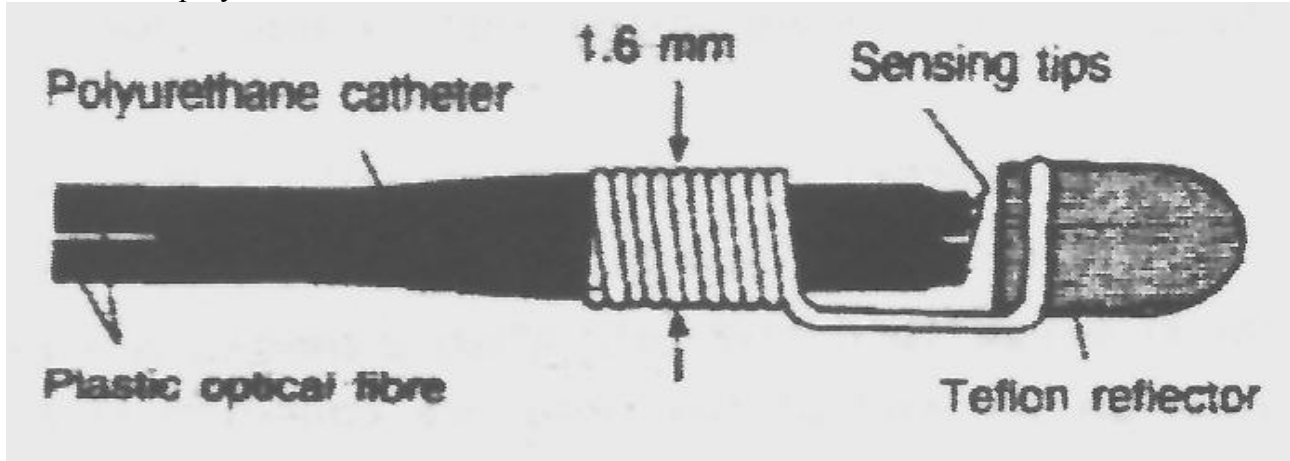
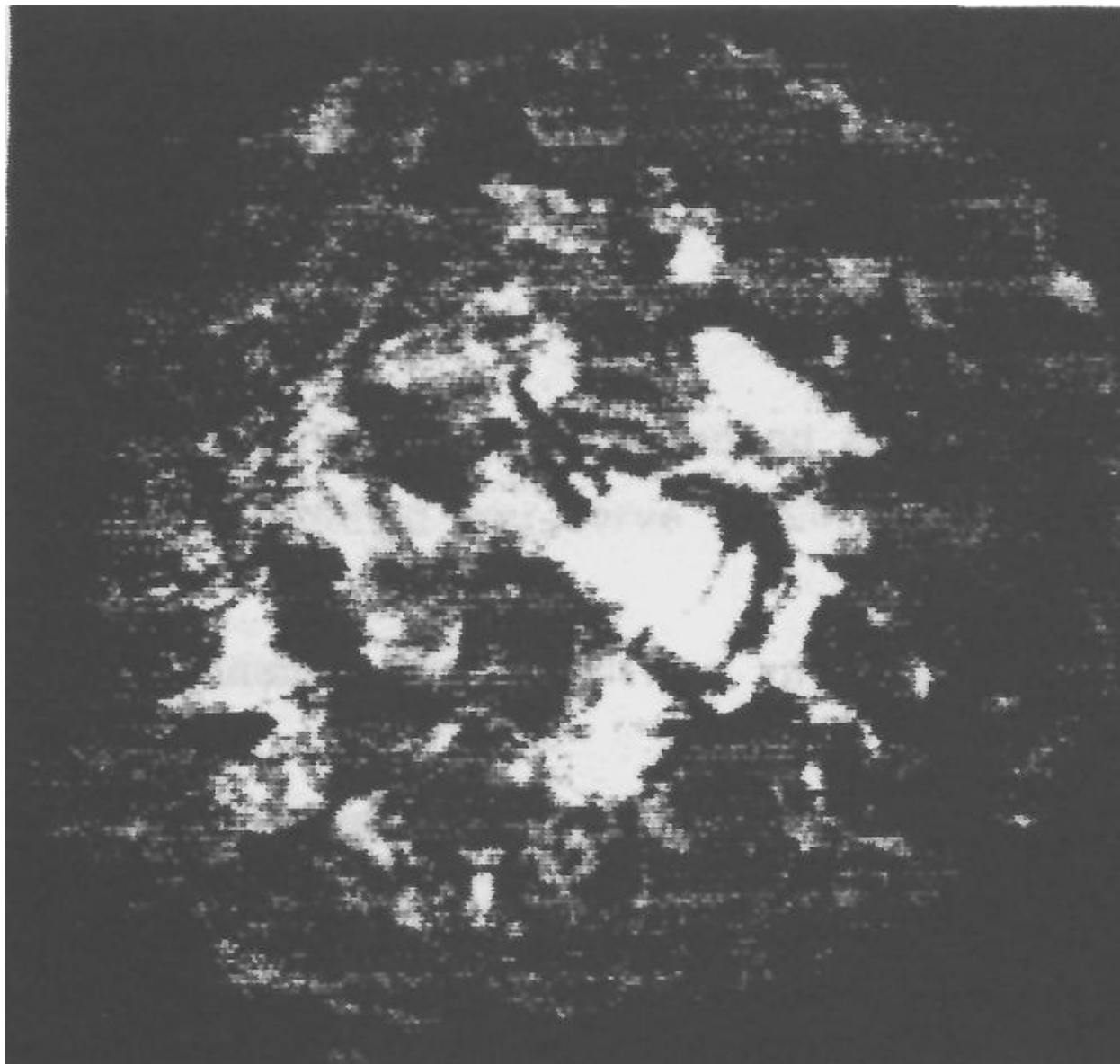

**FIGURE 2. Open optrode for pH measurements with bromophenol blue**

- 45 Light from the two sources passes to the optrode and then reflects back along the fibre and out of the second arm onto a photodetector, an amplifier and a processor.
- 46 The processor drives the two light sources and passes collected data to an internal buffer for transfer to an external computer.
- 47 Baldini has developed several designs for optrodes.
- 48 One is based on chromophores immobilised on glass microspheres in a stainless steel tube, which has perforations or slits in its wall.
- 49 Each of these "windows" is smaller than the spheres but large enough to allow liquids to enter.
- 50 An early optrode to measure acidity levels in the stomach was based on a tube 15 mm long by 0.8 mm in diameter, perforated with 70  $\mu\text{m}$  holes and containing a thymol blue chromophore immobilised on glass.
- 51 Test measurements show that the prototype is sensitive to 0.007 pH to 4 pH, but the response time of several minutes is too long, for my requirements for **STARSHIP EZEKIEL MK.V** Programme.
- 52 A narrower tube containing more holes would improve response times but the viscosity of gastric juices in vivo would reduce them again.
- 53 Although the perforated optrode was abandoned as a gastric monitor, a modified design with slits instead of holes measures the acidity of blood to 0.02 pH from 6.8 to 8 pH, with response times of about one minute for each 0.25 pH step.

## **MY MEDICAL KNOWLEDGE 1993.**

- 54 Well that is getting better.
- 55 However, can we improve on that timing period?
- 56 The chromophore is phenol red immobilised on polymer spheres and the sensor's sources emit at 570 nm for the signal and 660 nm for the reference.
- 57 Tubular optrodes are compact and simple.
- 58 They also suffer from slow leakage of the phenol red and, unless degassed, air bubbles reduce their typical response time of 30 seconds.
- 59 IROE has decided, therefore, that the design of the optrode is not suited to in vivo monitoring of acidity levels in blood.
- 60 Another optrode, designed to detect OXYGEN, is based on an organic metallic compound adsorbed onto a plate.
- 61 Such compounds, bis (histidinato) cobalt (II) in this case, change their absorbency spectra in the presence of OXYGEN.
- 62 A layer of SILICONE protects the compound, which is fixed to one wall of a flow cell.
- 63 The SILICONE allows the compound to react with liquids while protecting it from physical damage.
- 64 The 470 nm signal and 620 nm reference beams shine through a quartz window in the aluminium cell and reflect off the compound.
- 65 The optrode is accurate to 0.3 vol. percentage in the first 0 to 10-vol. percentage of OXYGEN in an OXYGEN -ARGON mixture.
- 66 In addition, is slightly less accurate at higher concentrations of OXYGEN.
- 67 Response time is about two minutes, depending on the thickness of the SILICONE layer.
- 68 One of IROE's most promising optrode designs exposes bare ends, or chromophore-carrying spheres fixed on the ends of fibres, to fluids such as gastric juices.
- 69 This open optrode design was used for the bile sensor, which has just gone on sale, and a version of the design is under test as an acid sensor.
- 70 At the end of a 500  $\mu\text{m}$  diameter polymer fibre is placed against a heated layer of glass microspheres, the polymer softens and up to 50 spheres carrying about 5 Ng of chromophore penetrate the tip.
- 71 When the polymer cools, it hardens and fixes the spheres in place.



**FIGURE 3. Glass spheres carrying a chromophore fixed to a 500  $\mu\text{m}$  Diameter polymer optical fibre.**

- 72 A Teflon reflector mounted by a wire in front of the bare or bead-carrying fibre tips improves the coupling of the signal and reference beams to create an optrode, which is open to gastric juices.
- 73 Its open structure allows liquids in the stomach to remove contaminants, such as mucus collected by the optrode as it is inserted through the nose and oesophagus, and so ensures a fast response from the sensor.
- 74 Measurements in vitro proved that an open optrode with bare fibre tips detects bilirubin to an accuracy of four  $\mu\text{mol}$  compared with the 0 to 100  $\mu\text{mol}$  range expected in the stomach.
- 75 Francesco Baldini reports that, based on over 100 in vivo measurements, bare fibre tips are better than conventional medical techniques for detecting bile.



## **MY MEDICAL KNOWLEDGE 1993.**

- 76 For example, the sensor can determine the moment when bile enters the stomach from the duodenum in conditions where conventional measurements do not even detect a change in acidity.
- 77 Other techniques, such as the injection of a radioactive marker, which is rapidly eliminated by the liver and bile ducts, record the presence of bile in the stomach.
- 78 However, radioactive markers, unlike the new sensor, cannot give information about the concentration of bile.
- 79 An open optrode, with spheres carrying bromophenol blue fixed to its fibre tips, has just begun in vivo trials to monitor acid levels inside the stomachs of patients.
- 80 The trials are in collaboration with Prof. Paolo Bechi of Clinica Chirurgica III at the University of Florence.
- 81 Two sources shine 595-nm signal and 870 nm reference beams down its 0.5-mm diameter fibres.
- 82 So far, the in vitro trials show that the optrode is accurate to  $\pm 0.05$  pH in the range of 3 to 7 pH, with a response time of a few seconds.
- 83 Now we are talking my kind of language that is more like what I wish to hear.
- 84 Baldini reports that hysteresis is greater in acid detection with the open designs than with the perforated stainless steel tube optrode.
- 85 "At the moment we can't give a sure interpretation of this because the only difference is the thickness of the beads," he says.
- 86 However, the effect of hysteresis with the open optrode is consistent enough to be removed by software.
- 87 The other good news about new acidity sensor is that its sensitivity is not affected by temperature and it can be stored in dry conditions for long periods.
- 88 Baldini now predicts the device will join the bile sensor on the market in about 18 months. I will be watching out for it.
- 89 This is only one subject matter where sensors will play a vital part of the **STARSHIP EZEKIEL MK.V. PROJECT**, other sensors will be discussed within these books.
- 90 I will change this point to another point, which often appears.

### **91 QUESTION**

Over the last two years, I have noticed that my penis becomes curved when I get an erection, I have seen my doctor, who has diagnosed **PEYRONIE'S DISEASE**.

## MY MEDICAL KNOWLEDGE 1993.

I am 22 and a virgin - and about to go away with my girlfriend, with whom I have a very caring and deep relationship.

I am sure that we will make love and I am worried that I will not be able to manage it.

Can you give me any advice?

### 92 ANSWER

My first piece of advice is not to worry.

**PEYRONIE'S DISEASE**, named after a French surgeon, is caused by harmless hard tissue, which pulls the penis to one side or another when you get an erection.

It rarely affects your ability to make love and is best forgotten about - unless it is painful or causes severe deformity, in which case your GP may want to refer you to a specialist.

I can tell you from actual experience that the pain can be beyond a limit, which would allow you to even think of trying to make love.

However, it was not **PEYRONIE'S DISEASE**, which was the cause of my problem; it was the lack of lovemaking.

Not all men have straight penises when erect.

I have seen some unusual sights in my career, one case that was a perfect Cork screw from base to tip, very, few of which ever interfere with Love making.

I must admit I do not know how the chap above managed, as it would need three times more space to accommodate it.

Indeed some men are proud of their individuality!

Enjoy your holiday.

93 In 1968, Peyronie's disease was unknown to me, so at that time I would not had known of that problem.

94 Strange as it may seem to one, as I reflect upon this matter, that during my training on the hospital ward, I did not know of such problems. Then let us face it, it is not a normal practice for men to erect themselves, just to show the medical staff what they got as a weapon.

95 To some people they may feel that these discussions are not important to the **STARSHIP EZEKIEL MK.V. PROJECT**, but that is where you go wrong.

96 The designer needs every bit of knowledge across the whole of humankind requirements.



***THE IMPOSSIBLE MADE POSSIBLE BY FOOLS LIKE SEARL.***

- 1 This is but one of the trains Searl operated on his system using the *S.E.G.* Technology
- 2 An articulated steam locomotive with tender of the Baltimore & Ohio Company, which again shows proof that the impossible can often become possible.
- 3 It has a wheel arrangement 2-8-8-0; somehow dream one has again popped in to say hello!
- 4 Projected by the USRA – United States Railway Administration, the loco group ED-5 of the B & O was built between 1919 and 1920 by the Baldwin locomotive company.
- 5 Well Dr. Edwards I bet you never knew that I knew that, but the question is did you know that?
- 6 They had the Baker distribution system and were equipped with a Vanderbilt type tender.
- 7 The B & O used the articulated locos to haul freight trains on the uneven lines of the Cumberland and on the severe ruling gradients of Cranberry, Cheat River, Newburg.

## REALITY OR FANTASY 1978.

Searl's rail system, which became public, shows locos operating on the **S.E.G.** principal.

- 8 Very powerful motor driving the two articulated motor groups through a longitudinal shaft and pendular transmission with universal joints.
- 9 Metal frame in spite of its considerable length this model has an exceptional smooth running and could negotiate curves down to 40 CMS. Radius thanks to the two articulated motor groups.
- 10 This model is extremely detailed and fully operating valve gear system
- 11 Length of this model was 40 CMS.
- 12 Of course, I can carry on and on about this train and its history, but the sole purpose of this article is to answer those idiots who claim by their expertise of bullshit that Searl never had anything.
- 13 You the reader have to make up your mind if Searl did have or not.
- 14 Was there such a model available, which he could, had brought matching the claims shown here?
- 15 Searl does not confirm that today it is still possible to buy a copy of this train, as he has been out of action for some time.
- 16 His sons, either sold at extreme stupid prices, as they had no knowledge of the cost of those engines stole all of his rail system, from the first to the second one.
- 17 Stupid people who have no common sense use this unfortunate situation to expose how clever they are in bullshitting.
- 18 That is the only reason they are experts.
- 19 They are sick in the mind, and represent the reason why this planet is in such a mess.
- 20 No other animal upon this planet does so much damage. This is a fact!
- 21 This is the man who gives his whole life to study the problems of this planet; his answer is to transfer all Homo sapiens to Mars. Then this planet will be a paradise.

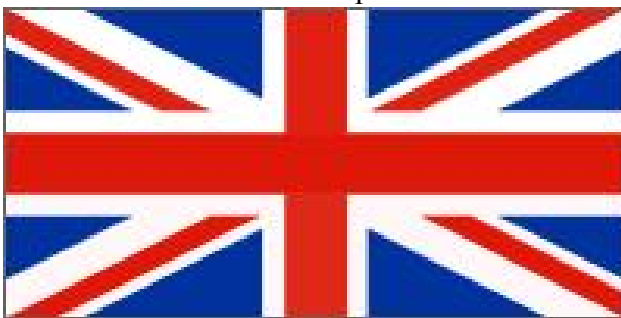

*Prof. John Roy Robert Searl Head of R&D Human Studies.  
Medical Division.*

**SEARL'S RAIL CONTROL SYSTEM 1968.**

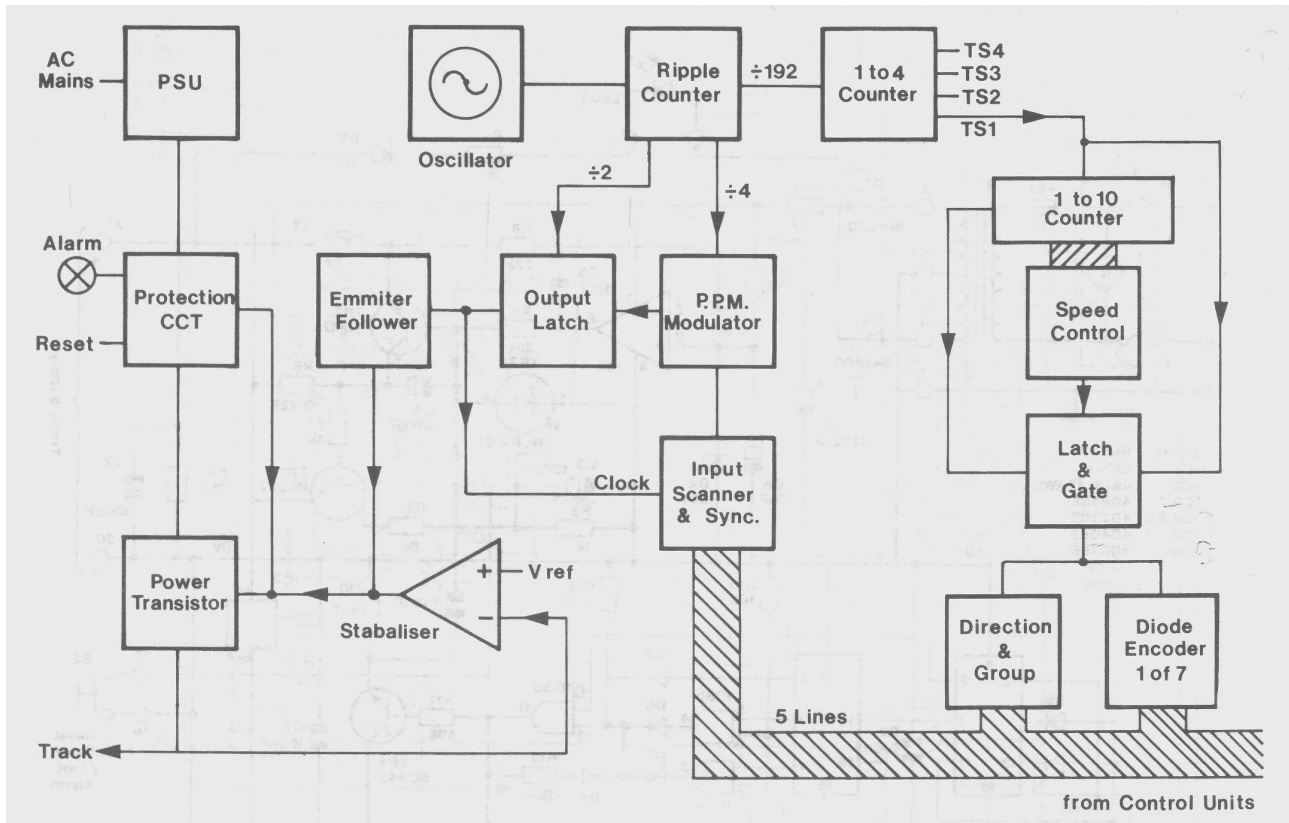

- 1 Yes, this gives you the insight how things progressed through time
- 2 It is a time-related project based upon cost and components availability.
- 3 The above diagram shows the common and control boards, bear in mind that at this time much of the controls were operated by a person name Searl.
- 4 Below is the receiver circuit.

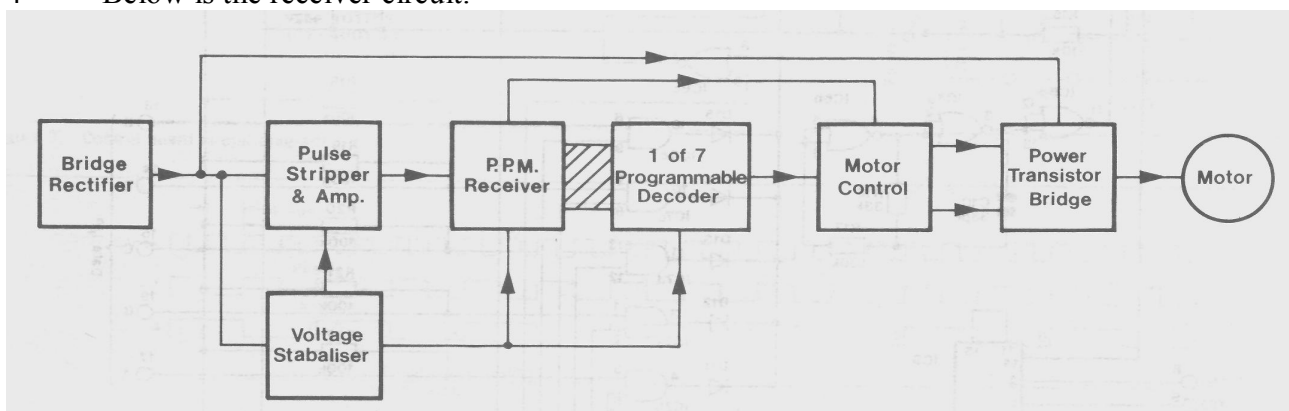

- 5 It was a great step forward from the masses of levels, which had been in use prior to this insertion to the system.
- 6 I may have already referred to this before; I feel that I should extend this information in details, because it could still be used if ever I could afford to replace that loss.



## SEARL'S RAIL CONTROL SYSTEM 1968.

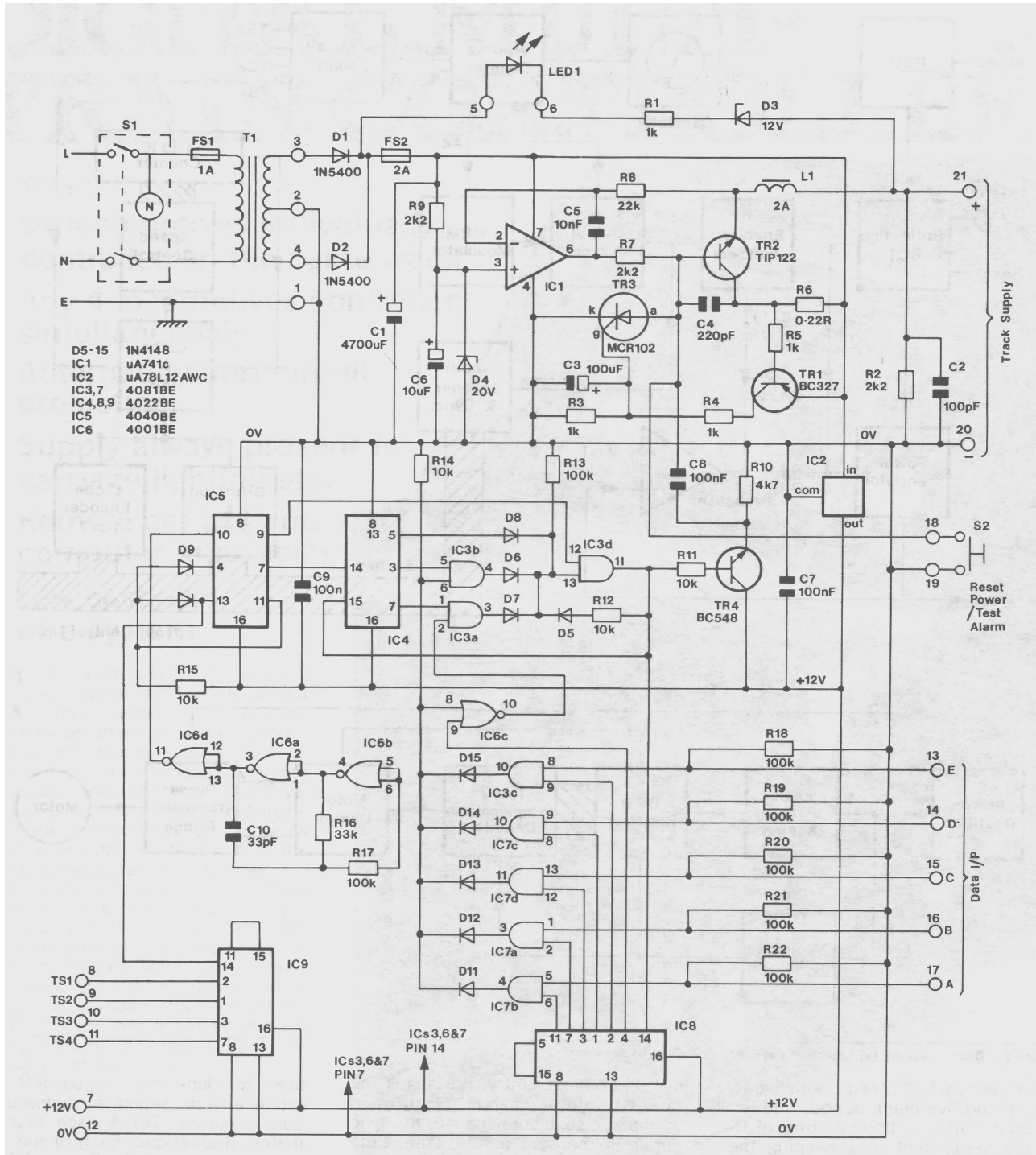

**Common board PSU circuit diagram.**

- 7 If you remember from my past books and newsletters that I wanted, because of the increased number of trains to be able to operate them faster in the effort to demonstrate that you can operate a real system by the same methods.
- 8 Up till 1968 the trains could be controlled manually, by masses of switches.
- 9 Unfortunate that did not represent much of a real business by rail.

## SEARL'S RAIL CONTROL SYSTEM 1968.

- 10 Here is the view of the completed control PCB, remember there is not just one off there are many of them.

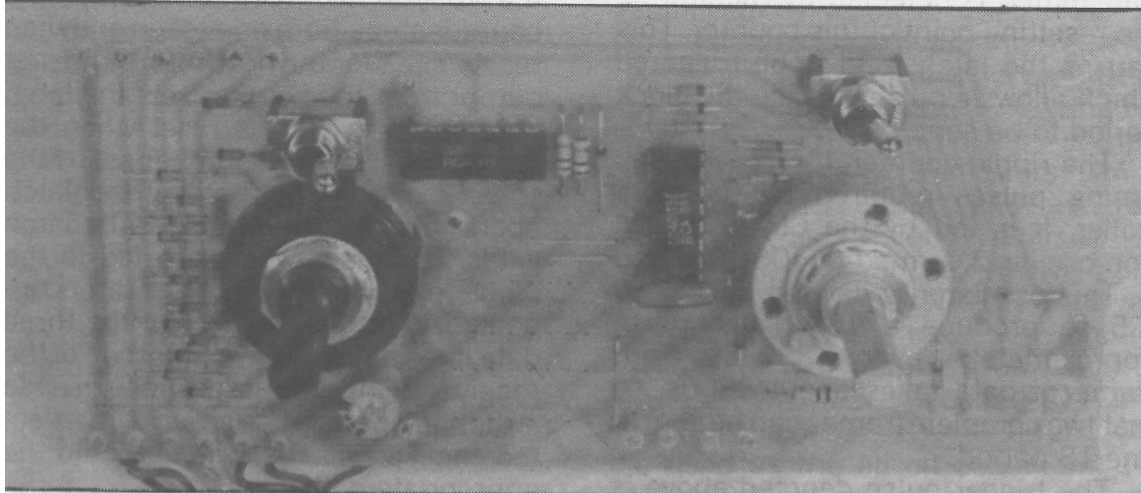

**Completed control PCB, sorry it has not come out very clear.**

- 11 Bear in mind at this time the operation is still controlled by manpower.
- 12 However, we can now speed up the system; therefore, more trains can operate.
- 13 As this is a demonstration of a real time business rail system, we shall need to operate far more trains without accident.
- 14 A model system must be able to perform the same operation requirements as that of a real business system
- 15 Searl through his model rail system must bring out of the world of fantasy into the world of reality that which sits in his mind.
- 16 Until he has modelled it, no one can really appreciate what he states possible.
- 17 Thus in 1968 he has to change much of his rail system, which is rather elementary stuff Dear John to something more complex, yet still logic in operation.
- 18 That calls for a lot of research for the components to be able to bring out of Searl's mind that which you cannot see. Therefore, you too can see what he states.
- 19 Searl appreciated that if he went digital in thinking and construction followed suit; he would be able to have multi-train control.
- 20 Up to 1968 Searl had just 14 locomotives operating over the same track.
- 21 One can appreciate that 14 trains running over the same track by the class of switching supplied at that time, is time consuming, and thus a slow process.
- 22 Not only children like model rail layouts, so doe's adults, maybe much more than children do.



**PROF. JOHN ROY ROBERT SEARL**  
**Author, Inventor, President, S.I.S.R.C.**

Prof. Searl is the inventor of the **SEARL EFFECT GENERATOR, S.E.G.**, which is its own prime mover and generates electricity. He has written a series of books entitled “The Law of the Squares.”

Prof. Searl looks at things differently from most people in that he equates everything to “The Law of the Squares.” He is only interested in the Truth in all things. He has written his books to dispel all the miss-information and lies that have been written about him and his work.

He is setting the record straight. These books tell of his life experiences as well as the technology that he has developed. After reading these books, you may look at things differently.

He is currently President and Consultant Engineer of the *Searl International Space Research Consortium (S.I.S.R.C.)* Prof. Searl is truly trying to bring us into a better future through this method of thinking and the technology that it has produced. Sorry this is the end of chapter 17. May the power be with you always, take care; I am watching you watching me watching you the future looks bright turn up the light and be seen.